

Edition 0109



Loading Dock Supply LLC
PO Box 15 Ashley, Ohio 43003
Phone 1-800-741-1258
Fax 1-866-709-2802

1-800-741-1258 • LoadingDockSupply.com



DURA-SOFT BUMPERSTM • EXTRUDED DOCK BUMBERS • CORNER GUARDS • STEEL-FACE DOCK BUMBERS
LAMINATED DOCK BUMBERS • EXTRA-THICK LAMINATED DOCK BUMBERS • MOLDED DOCK BUMPER
WHEEL CHOCKS • PARKING BLOCKS/SPEED BUMPS • WHEELRISERS • PLATFORMS • DOCKLEVELERS
ALUMINUM DOCKBOARDS • STEEL DOCKBOARDS • WALKRAMPS • MODULAR LOADING DOCK LIGHTS
FULLY ASSEMBLED LOADING DOCK LIGHTS • LEVELER ACCESSORIES • TRACK GUARDS • COMPRESSION SEALS
STRIP DOORS AND PVC MATERIAL • STRIP DOOR HARDWARE • STOP AND GO SIGNAL SYSTEM

ORDERING INFORMATION

For product inquires & quotations ask for **Sales...** for placing Orders & Delivery information ask for **Customer Services.**



800-741-1258

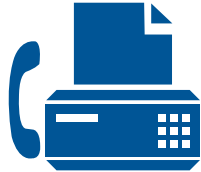

866-709-2802



P.O. Box 15
Ashley, OH 43003



sales@loadingdocksupply.com

Office Hours

Monday through Friday from 8:00 am to 7:00 pm EST, call toll free in the Continental USA (800-741-1258), or email us at sales@loadingdocksupply.com. A knowledgeable Customer Services Representative will be happy to help you. After hours, call the same number and leave a message on our voice mail system. A Customer Services Representative will contact you promptly in the morning on the next business day.

Placing Order

There are five easy ways to place an order:

1. Fax in your order:866-709-2802
2. Phone our toll free number 800-741-1258
3. Email your order: sales@loadingdocksupply.com
4. Mail in your purchase order
5. On line at www.loadingdocksupply.com

Setting up an Account

We can usually arrange for credit quickly and easily. All you need to do is fill out our Customer Information Sheet which requests all the usual business, bank and credit information.

Terms

All orders are shipped FOB Origin. Freight charges are prepaid and added to the invoice, unless otherwise requested. If there are any taxes, duties or fees for customs, they are the responsibility of the customer. For our convenience, we also accept Master Card, Visa and American Express.

Warranties and Guarantees

All products offered by Loading Dock Supply are guaranteed to be free of defects in material and workmanship under normal conditions of usage, provided our recommended installation and maintenance instructions are followed. We will not be liable for damage in excess of the purchase price of the product.

TABLE OF CONTENTS

Dock Protection Guide	3
Dura Soft Bumpers	4
Extruded Dock Bumpers	5
Corner Guards.....	5
Steel Faced Bumpers	6
Laminated Dock Bumpers.....	7
Extra Length Laminated Dock Bumpers.....	8
Extra Thick Laminated Dock Bumpers	9
Molded Dock Bumpers.....	10
Wheel Chocks	11
Parking Block	11
Speed Bumps.....	11
Wheel Risers.....	12
Steel Platforms	12
Dock Levelers	13
Leveler Accessories & Track Guards	14
Aluminum Dock Boards	15
Steel Dock Boards	16
Red Pin Steel Dock Boards	17
Rail Boards	17
Dock Board Selection Guide.....	18
Walk Ramps.....	19
Modular Loading Dock Lights	20
Assembled Dock Lights	21
Dock Lighting Guide.....	22
Stop and Go Lights.....	23
Strip Doors & PVC Material	24
Strip Door Hardware	25
Compression Seals	26
Compression Seal Designs	27
Dock Survey Form.....	28
Helpful Facts About Loading Docks	29

DOCK PROTECTION GUIDE

SELECT DURABLE'S EXPERIENCE

Various factors comprise the loading dock system and contribute to the efficient transfer of goods and materials. Dock bumpers, dock levelers, dock lights, dock height, wheel chocks, and door seals or shelters should all be considered when designing a dock system. Contact us, and we will be happy to help you create the most cost-effective bumper system available.

DOCK BUMPER ARRANGEMENTS

Most dock bumper installations should have vertical and horizontal coverage of the dock area for complete dock, truck and cargo protection.

For example, protection for an 8' bay is usually best accomplished with two vertical bumpers and one horizontal bumper of standard length. Our optional overlapping arrangements provide continuous protection and minimize installation costs. An additional row guarantees protection for vehicles of various heights.

When dock seals or shelters are used, extra-length, one-piece bumpers will completely seal trucks to the dock protecting cargo and employees from the elements.

BUMPER HEIGHTS

Durable's standard bumper heights are 6", 10", or 12". The height can be increased by expanding the angle length and "stacking" bumper pads between them to create vertical units—20", 24", and 36".

The primary application for the 6" unit is on lip docks where the dock slab projects beyond the foundation with an impact face of less than 10" high.

The heavier constructed 12" unit provides greater area and cube of rubber with a stronger steel frame (three connecting rods).

The 20", 24", or 36" vertical heights provide extended depth protection for varying truck heights (Fig. 1) for the lower steel members of trailer bodies. Consider them for docks that accommodate panel and peddle trucks as well as over-the-road trailers.

Vertical units are particularly applicable with truck leveling devices that raise the entire truck to dock level. Combined with horizontal units, (Figs. 3 & 4), vertical units prevent a loaded trailer from prying off the shorter bumpers as the truck bed rises while being unloaded (Fig. 2).

FOR OPEN DOCKS

For open docks with no predetermined truck spots, combination installations provide maximum protection (Fig. 3).

If 36" horizontal length units are used, maximum spacing should be 24" between units—5' on centers (Fig. 6).

For an angled truck approach, spacing should be reduced to prevent a truck corner from contacting the dock between units.

If continuous bumper protection is needed, overlapping installations on common anchor bolts are recommended and reduce anchor bolt costs by 50% (Fig. 5).

Overlapping reduces the spacing between each bumper to 4", and is applicable to any Durable laminated bumper model.

Overlapping angles on adjacent bumpers cuts installation costs and increases the protected area. To order, specify standard model for first bumper at left, and "OL" construction on successive bumpers. Special-length bumpers to fill out dock spaces are also available.

For open docks or wide bays, extra-length, one-piece bumpers can also be used for maximum coverage and appearance (Fig. 7).

FOR 8', 9', OR 10' BAYS

For 8', 9', or 10' bays a variety of combinations exist. We recommend a combination of standard and vertical bumper designs (Fig. 3 & 4) for dock protection.

FOR REFRIGERATED DOORS

(with or without dock shelters)

Refrigerated doors require 4-1/2" or 6" thick, extra-length, one-piece bumpers to completely seal the truck to the dock or shelter.

The same applies to doors sealed to maintain warm temperatures. With shelters, the rubber surface of the bumper must extend under the vertical members of the shelter pad to complete the all-around seal (Fig. 7).

FOR PORTABLE DOCK PLATES

A 36" unit mounted in the center of the dock will automatically allow for dock plate insertion, even if a truck is spotted against the bumpers at the dock. With 3" angles on all bumpers, a 6" space is provided between units for the legs of the dock plate. Continue to fill the width of the bay with standard or vertical units as needed.

FOR ADJUSTABLE DOCK BOARDS

If using 14" lengths, height should be minimum 12", (Figs. 8a, 8b). Most dock boards handle 4-1/2" or 6" thick bumpers and will not impair lip penetration into the truck.

If using horizontal bumpers, use similar to 24" units but with steel plate replacing the inboard angle. Fig. 9 shows damage from "short spacing". Fig. 10 shows "lateral safety zone" impact absorption advantage provided by longer bumpers.

BUMPER INSTALLATION

Install bumpers (Fig. 11) 1" to 2" below dock level. Use 3/4" or 5/8" lag bolts or sleeve anchors; minimum 3" and use corresponding shield if required. Use 3/4" "J" bolts with a minimum length of 8" with 1-1/4" projection.

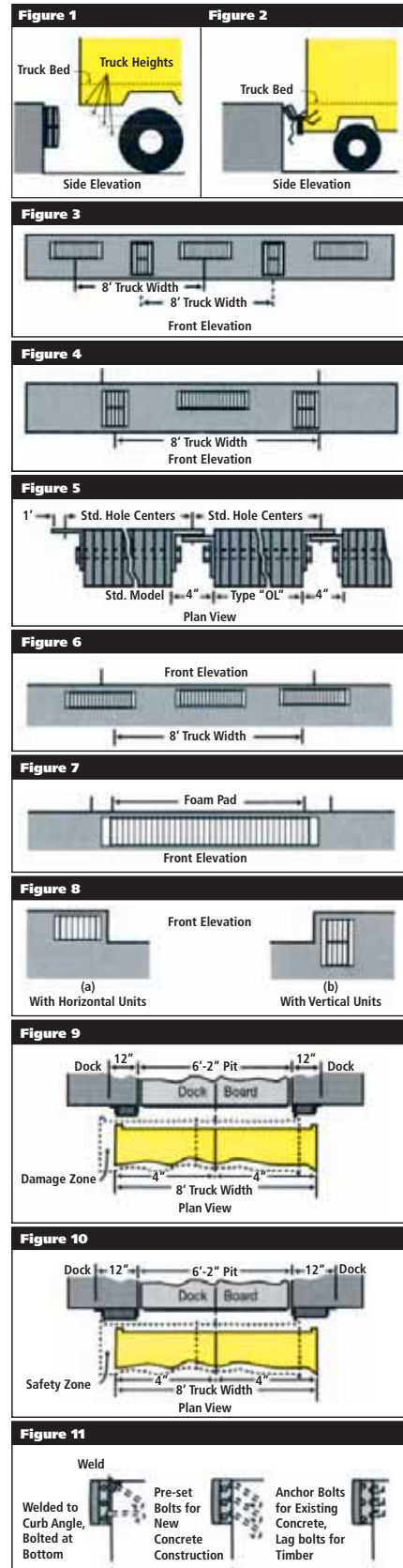



USES/APPLICATIONS

- Provides maximum protection with a unique “loop” design of bumper pads—the greatest impact absorption available on the market. Loop-design laminated bumper is a Durable industry innovation.
- Durable’s patented design has been thoroughly tested to prove that it provides maximum protection while maintaining the high-quality, heavy-duty dock and truck protection expected of a Durable bumper.
- Steel-Face plate makes the Dura-Soft Bumper™ ideal for use in docking areas where excessive friction from up-and-down trailer movement occurs.
- Can be used in any material-handling system area where heavy-duty protection is required.



FEATURES

- Unparalleled ability to deflect and absorb shock with loop design laminated bumper beneath a floating steel-face.
- Available in a wide variety of models, and can be mounted in various heights, from flush mount to 12” above dock, depending on highest impact area.

BENEFITS

- Maximum dock and truck protection available.
- Eliminates wear from up-and-down friction movement of trailer loading and unloading.
- Impervious to weather damage.
- Maintenance free.
- 5 year warranty.
- Cost effective.

MATERIAL/THICKNESS

- Rubber pads 4” thick with loop pad and 3/8” steel-face for overall thickness at 5-1/2”.

INSTALLATION

- Structural mounting angles permit welded installations or provide bolting through steel.
- No assembly required.

SPECIFICATIONS

- Resilient rubber material of bumpers shall be cut to uniform size pads 4” thick with overall projection of 5-1/2”. Longer, looped pads inserted between standard spacer pads to allow approximately 1/2” flex of looped pads upon impact. Pads punched to receive 3/4” supporting rods.
- Bumper to have 3/8” steel-face plate equal to the rubber surface dimensions. Plate to be welded to slotted steel support plates which extend back to the 3/4” supporting rods. Brackets to be punched with elongated slots to allow steel-face to “float” on impact.
- Finish to be black only.

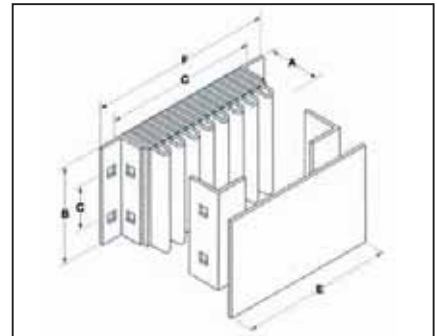

Model	Projection x Height x Bolt Hole Centers (Length) (A x B x C) Size	D Vertical Bolt Hole Centers	E Rubber Length	F Overall Length	Wt. lbs.
B5510-14-DS	5-1/2" x 10" x 14"	6"	10"	16"	48
B5510-18-DS	5-1/2" x 10" x 18"	6"	14"	20"	58
B5510-24-DS	5-1/2" x 10" x 24"	6"	20"	26"	73
B5510-36-DS	5-1/2" x 10" x 36"	6"	32"	38"	72
B5512-14-DS	5-1/2" x 12" x 14"	4"	10"	16"	35
B5512-18-DS	5-1/2" x 12" x 18"	4"	14"	20"	44
B5512-24-DS	5-1/2" x 12" x 24"	4"	20"	26"	58
B5512-36-DS	5-1/2" x 12" x 36"	4"	32"	38"	84
B5520-11-DS	5-1/2" x 20" x 11"	6"	7"	13"	73
B5524-11-DS	5-1/2" x 24" x 11"	4"	7"	13"	56
B5536-11-DS	5-1/2" x 36" x 11"	4"	7"	13"	85

EXTRUDED DOCK BUMPERS



USES/APPLICATIONS

- Appropriate for outdoor and indoor protection.
- For commercial loading docks, parking garages, and marinas.
- For vehicles such as tow trucks, trailers and heavy duty construction equipment.
- In-plant wall protection from forklifts and other material handling vehicles.

FEATURES

- Variety of styles available for greater flexibility.
- Can be pre-drilled for immediate installation.

BENEFITS

- Installs easily
- Eliminates costly and unsightly damage to equipment, vehicles and structures.
- Resistant to all types of weather.
- One piece construction.
- One year warranty.

Model	A Thickness	B Height	Length	Bolt Size	Wt. lbs.	Color
D-2	1-3/4"	2"	Up to 10'	1/4" x 2"	1.4 lbs/ft	Black
D-4	4"	4-1/4"	Up to 10'	1/2" x 3"	3 lbs/ft	Black
D-6	6"	6"	Up to 10'	1/2" x 3"	8.5 lbs/ft	Black
E 1 1/2" (38.1mm)	1-1/2"	8"	Up to 10'	3/8" x 3-3/4"	6.5 lbs/ft	Black

NOTE: All dimensions are approximate.

MATERIAL THICKNESS

- Made of solid rubber for medium and heavy-duty protection.
- All bumpers have impact resistance (ASTM 2632) of 75% with a durometer reading of 70 plus or minus 5.
- D-4 and D-6 available with steel mounting bars.

INSTALLATION

- Anchor bolts easily installed through pre-drilled holes into dock.

SPECIFICATIONS

- Resilient molded nylon and polyester reinforced rubber as well as rubber bumpers.
- Bumpers are made of rubber with a durometer reading of 70 plus or minus 5. Tensile strength of 1,850 PSI with an elongation of 220%. The tear strength (ASTM 624) is 229 pounds per inch with impact resistance (ASTM 2632) of 75%.

CORNER GUARDS

USES/APPLICATIONS

- Wide variety of uses in industrial and commercial applications to withstand abrasion and jolts.
- Provide maximum protection in storage spaces, parking garages and loading docks.

FEATURES

- Mounted vertically or horizontally along the corners of walls or beams to prevent damage.
- Heavy-duty flexible compound prevents damage to equipment and vehicles to save money.



BENEFITS

- Easy installation.
- Maintenance free.
- Tough and long-lasting in severe weather.
- One year warranty.

MATERIAL/THICKNESS

- Made of all natural rubber.
- 7/8" thick at corner.

INSTALLATION

- Adhesive and/or mechanical fasteners for permanent protection.

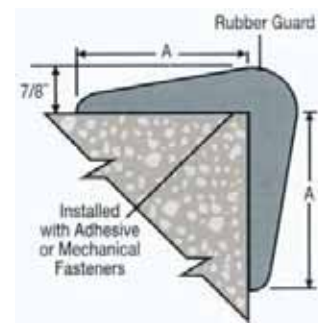

Model	Thickness	A Width	Length	Weight lbs.	Color
CG-1	7/8"	4"	Up to 10'	2.6 lbs/ft	Gray
CG-2	7/8"	4"	Up to 10'	2.6 lbs/ft	Black



STEEL-FACE DOCK BUMPERS

BENEFITS

- Eliminates wear from up-and-down friction movement of trailers loading and unloading.
- Cost-effective due to longer wear expectancy and fewer replacement costs.
- Impervious to weather damage.
- Maintenance free.
- 5 year warranty

MATERIAL/THICKNESS

- Fabric reinforced pads cut from selected recycled truck tires.
- Standard pad thickness at 4-1/2" and 6" thick. Heights at 6", 10", and 12".
- Steel-face is 3/8" thick, heavy-duty, high carbon steel that is mounted to standard laminated dock bumper.
- Also available in extra-thick sizes of 9", 10-1/2", and 12" projections.

INSTALLATION

- Structural mounting angles permit welded installations or provide bolting through steel.
- No assembly required.

SPECIFICATIONS

- Resilient rubber material cut to uniform size pads 4-1/2" thick with overall projection of 5-1/4" [other pad thicknesses available: 6", 9", 10-1/2", and 12"]. Punched to receive 3/4" supporting rods.
- Bumper to have 3/8" steel-face plate equal to the rubber surface dimensions. Plate to be welded to two slotted steel support plates which extend back to the 3/4" supporting rods. Brackets to be punched with elongated slots to allow steel-face to move on impact.
- Finish to be black only.

USES/APPLICATIONS

- Ideal for use in docking areas where excessive friction from up-and-down trailer movement occurs.
- Can be used in any material-handling system area where heavy-duty protection is required.

FEATURES

- Available ability to deflect and absorb shock with standard laminated bumper beneath the steel-face.
- Comes in a wide variety of models, and can be mounted in various heights, from flush mount to 12" above dock, depending on highest impact area.

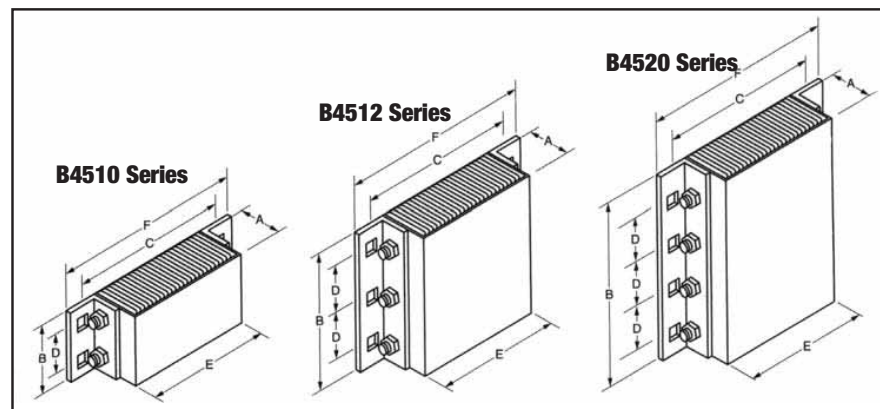
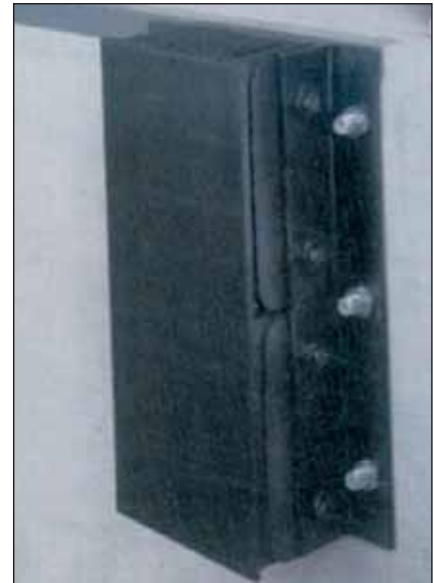

Model	Projection x Height x Bolt Hole Centers (Length) (A x B x C) Size	D Vertical Bolt Hole Centers	E Rubber Length	F Overall Length	Wt. lbs.
B4510-14-SF	5-1/4" x 10" x 14"	6"	10"	16"	48
B4510-18-SF	5-1/4" x 10" x 18"	6"	14"	20"	58
B4510-24-SF	5-1/4" x 10" x 24"	6"	20"	26"	73
B4510-36-SF	5-1/4" x 10" x 36"	6"	32"	38"	72
B4512-14-SF	5-1/4" x 12" x 14"	4"	10"	16"	35
B4512-18-SF	5-1/4" x 12" x 18"	4"	14"	20"	44
B4512-24-SF	5-1/4" x 12" x 24"	4"	20"	26"	58
B4512-36-SF	5-1/4" x 12" x 36"	4"	32"	38"	84
B4520-11-SF	5-1/4" x 20" x 11"	6"	7"	13"	73
B4524-11-SF	5-1/4" x 24" x 11"	4"	7"	13"	56
B4536-11-SF	5-1/4" x 36" x 11"	4"	7"	13"	85
B610-14-SF	6-3/4" x 10" x 14"	6"	10"	16"	33
B610-18-SF	6-3/4" x 10" x 18"	6"	14"	20"	40
B610-24-SF	6-3/4" x 10" x 24"	6"	20"	26"	55
B610-36-SF	6-3/4" x 10" x 36"	6"	32"	38"	82
B612-14-SF	6-3/4" x 12" x 14"	4"	10"	16"	39
B612-18-SF	6-3/4" x 12" x 18"	4"	14"	20"	50
B612-24-SF	6-3/4" x 12" x 24"	4"	20"	26"	72
B612-36-SF	6-3/4" x 12" x 36"	4"	32"	38"	105
B620-11-SF	6-3/4" x 20" x 11"	6"	7"	13"	53
B624-11-SF	6-3/4" x 24" x 11"	4"	7"	13"	64
B636-11-SF	6-3/4" x 36" x 11"	4"	7"	13"	100

NOTE: Available in 9" thick pads with an overall 9 3/4" projection. Other standard sizes available.



LAMINATED DOCK BUMPERS

USES/APPLICATIONS

- Available in two models: bumpers with angles for most applications—equipped with 1/4" steel angles on both ends; and bumpers with flat plate for use with dock levelers—optional 1/4" flat steel plate for one or both ends.
- Have unlimited applications in factories, warehouses and docks.
- Vehicle impact protection for loading docks.
- Protecting above low docks.
- Rub rails at the sides of truck wells.
- Wall bumpers to protect against fork lift trucks.
- Special construction features to accommodate unusual anchoring conditions.

FEATURES

- Tough plies of truck tire material virtually eliminates chipping or abrasion, unlike molded rubber, extruded rubber, conveyer belting or wood plank bumpers.
- Attractive deep black color enhances a neat, professional architectural look.
- Manufactured under pressure exceeding 1,500 lbs. to absorb over 80% of impact force.
- Anchor bolts are protected by at least 3" of rubber to prevent damage.

BENEFITS

- Provides protection against vehicle damage to docks, buildings and cargo.
- Absorbs over 80% of truck impact and shock to protect dock and building.
- Leading bumper sold in the industry today.
- Standard sizes shipped within 24 hours.
- Eliminates costly repairs from severe shock to docks.
- Constructed to last and provide years of protection.
- Anchored through thick steel angles to provide stability and shape retention.
- Performs on any truck dock under any weather condition or prolonged exposure.
- Maintenance free. 5 year warranty.

MATERIAL/THICKNESS

- Fabric reinforced rubber pads cut from selected recycled truck tires.
- Rubber pads laminated between structural steel angles and secured with 3/4" steel tie rods.
- Rubber pads 4-1/2" or 6" thick.

INSTALLATION

- Structural mounting angles permit welded installations or provide bolting through steel.

SPECIFICATIONS

- Resilient rubber material of bumpers shall be rubberized-fabric trunk tires cut to uniform size pads and punched to receive 3/4" supporting rods.
- All bumpers must be 4-1/2" or 6" thick (projection from dock), and closed with two 1/4" structural angles under approximately 1,500 lbs of pressure.
- The anchor leg of angle extends a minimum of 3" beyond the rubber surface at either end and contains two or three 13/16" anchor bolt holes as required. (Anchor bolts are supplied separately.)
- Black finish.
- Galvanized exposed metal or all metal available upon request, surcharges apply.

Model	Projection x Height x Bolt Hole Centers (Length) (A x B x C) Size	D Vertical Bolt Hole Centers	E Rubber Length	F Overall Length	Wt. lbs.
B4506-24	4-1/2" x 6" x 24"	3"	20"	26"	28
B4506-36	4-1/2" x 6" x 36"	3"	32"	38"	42
B4510-12	4-1/2" x 10" x 12"	6"	8"	14"	25
B4510-14	4-1/2" x 10" x 14"	6"	10"	16"	26
B4510-18	4-1/2" x 10" x 18"	6"	14"	20"	34
B4510-24	4-1/2" x 10" x 24"	6"	20"	26"	45
B4510-36	4-1/2" x 10" x 36"	6"	32"	38"	66
B4512-12	4-1/2" x 12" x 12"	4"	8"	14"	31
B4512-14	4-1/2" x 12" x 14"	4"	10"	16"	32
B4512-18	4-1/2" x 12" x 18"	4"	14"	20"	41
B4512-24	4-1/2" x 12" x 24"	4"	20"	26"	56
B4512-36	4-1/2" x 12" x 36"	4"	32"	38"	82
B4520-11	4-1/2" x 20" x 11"	6"	7"	13"	42
B4524-11	4-1/2" x 24" x 11"	4"	7"	13"	51
B4536-11	4-1/2" x 36" x 11"	4"	7"	13"	85
B610-12	6" x 10" x 12"	6"	8"	14"	29
B610-14	6" x 10" x 14"	6"	10"	16"	33
B610-18	6" x 10" x 18"	6"	14"	20"	43
B610-24	6" x 10" x 24"	6"	20"	26"	58
B610-36	6" x 10" x 36"	6"	32"	38"	84
B612-12	6" x 12" x 12"	4"	8"	14"	34
B612-14	6" x 12" x 14"	4"	10"	16"	41
B612-18	6" x 12" x 18"	4"	14"	20"	51
B612-24	6" x 12" x 24"	4"	20"	26"	69
B612-36	6" x 12" x 36"	4"	32"	38"	105
B620-11	6" x 20" x 11"	6"	7"	13"	52
B624-11	6" x 24" x 11"	4"	7"	13"	63
B636-11	6" x 36" x 11"	4"	7"	13"	100

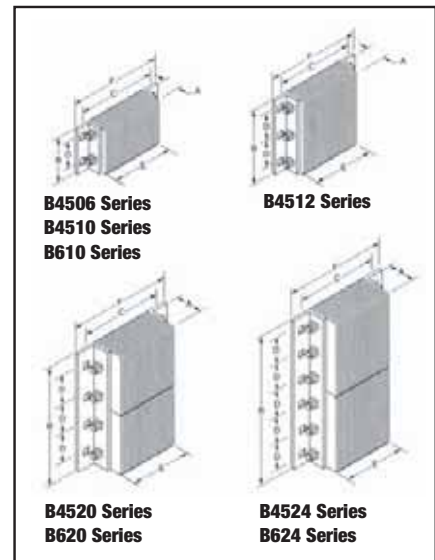

EXTRA-LENGTH LAMINATED DOCK BUMPERS



MATERIAL/THICKNESS

- Made of tough rubberized fabric pads, 4-1/2" or 6" thick cut from selected recycled truck tires.
- Rubber pads laminated between heavy structural steel angles and secured with 3/4" steel tie rods.

INSTALLATION

- Structural mounting angles permit welded installations or provide bolting through steel.
- Four options for anchorage devices for extra-length bumpers.

SPECIFICATIONS

- Resilient rubber material of bumpers shall be rubberized-fabric truck tires cut to uniform size pads either 4-1/2" x 10", 6" x 10", 4-1/2" x 12" or 6" x 12". Pads punched to receive 3/4" supporting rods.
- All bumpers are closed with two 1/4" structural angles under approximately 1,500 lbs of pressure. The angles are welded to 3/4" rods at one end and closed with threaded rod and nut at the other end. 1/4" flat plates may be substituted for one or both angles.
- The anchor leg of angle extends a minimum of 3" beyond the rubber surface at either end and contains two or three 13/16" anchor bolt holes as required. (Anchor bolts are supplied separately.)
- Black finish.

USES/APPLICATIONS

- Primarily used in conjunction with dock-seal.
- Ideal where dock refrigeration or warmth is needed.

FEATURES

- Dock-seal and bumper interact to totally seal the truck to the dock.
- Provides continuous protection for truck, cargo, dock and shelter to stop wind, snow and rain.
- Custom lengths available.

BENEFITS

- Prevents loss of refrigeration or warmth.
- Maintenance free—weather resistant.
- Absorbs over 80% of truck impact and shock to protect dock and building.

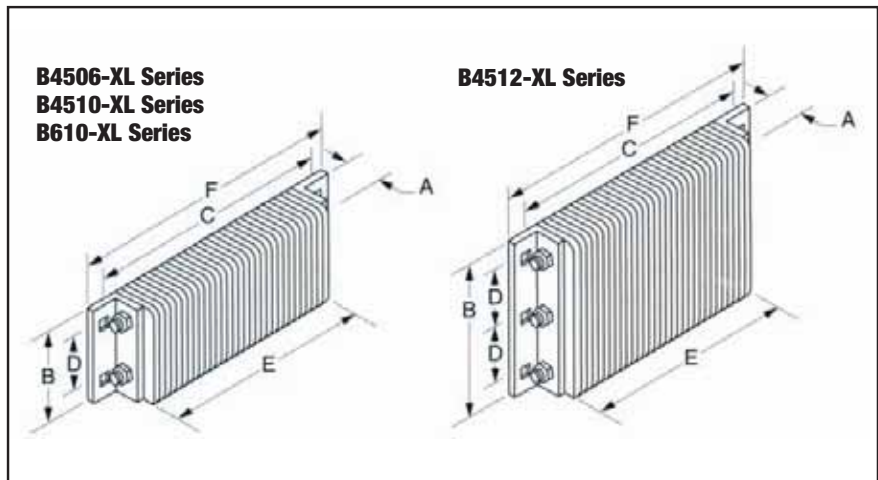
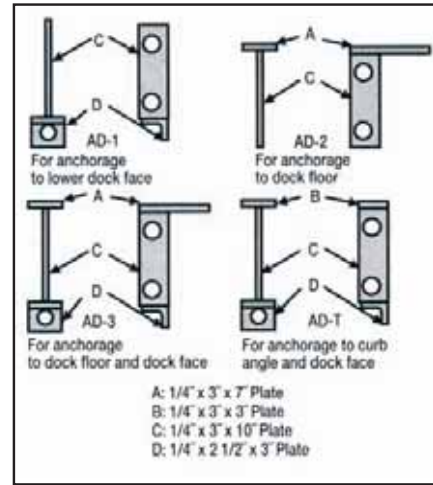

Model	Projection x Height x Bolt Hole Centers (Length) (A x B x C) Size	D Vertical Bolt Hole Centers	E Rubber Length	F Overall Length	Wt. lbs.
B4506-87-A*	4-1/2" x 6" x 7'3"	3"	6'-11"	7'-5"	98
B4506-99-A*	4-1/2" x 6" x 8'3"	3"	7'-11"	8'-5"	121
B4510-51-A*	4-1/2" x 10" x 4'3"	6"	3'-11"	4'-5"	101
B4510-63-A*	4-1/2" x 10" x 5'3"	6"	4'-11"	5'-5"	124
B4510-75-A*	4-1/2" x 10" x 6'3"	6"	5'-11"	6'-5"	147
B4510-87-A*	4-1/2" x 10" x 7'3"	6"	6'-11"	7'-5"	172
B4510-99-A*	4-1/2" x 10" x 8'3"	6"	7'-11"	8'-5"	193
B4510-111-A*	4-1/2" x 10" x 9'3"	6"	8'-11"	9'-5"	218
B4510-123-A*	4-1/2" x 10" x 10'3"	6"	9'-11"	10'-5"	238
B4512-51-A*	4-1/2" x 12" x 4'3"	4"	3'-11"	4'-5"	120
B4512-63-A*	4-1/2" x 12" x 5'3"	4"	4'-11"	5'-5"	148
B4512-75-A*	4-1/2" x 12" x 6'3"	4"	5'-11"	6'-5"	175
B4512-87-A*	4-1/2" x 12" x 7'3"	4"	6'-11"	7'-5"	202
B4512-99-A*	4-1/2" x 12" x 8'3"	4"	7'-11"	8'-5"	230
B4512-111-A*	4-1/2" x 12" x 9'3"	4"	8'-11"	9'-5"	258
B4512-123-A*	4-1/2" x 12" x 10'3"	4"	9'-11"	10'-5"	284

*Refer to illustration AD-1, AD-2, AD-3 or AD-T for type of anchorage device. AD-3 is standard unless otherwise specified.
 NOTE: 6" projection also available in standard sizes.

EXTRA-THICK LAMINATED DOCK BUMPERS

USES/APPLICATIONS

- Where greater “stand out” distance from dock sills is required due to steep ramps, canopied docks, overhangs or other architectural features.

FEATURES

- Consists of tough plies of truck tire fabric which virtually eliminates chipping or abrasion.

BENEFITS

- Maintenance free, weather resistant.
- Prevents damage to trucks, loading docks and buildings by providing greater stand-out distance from dock sills on steep ramps.
- Protects dock seals from over-compression.

SPECIAL NOTES

- Refer to stand-out distance planner to choose proper thickness for incline docks.
- **Extra-Thick bumpers are not under warranty due to specialty applications where they are used.**

MATERIAL/THICKNESS

- Uniform size, fabric reinforced rubber pads cut from selected recycled truck tires in 9”, 10-1/2”, and 12” projections.

INSTALLATION

- Structural mounting angles permit welded installations or provide bolting through steel (as opposed to bolting through rubber).
- No assembly required.

SPECIFICATIONS

- Resilient rubber material of bumpers shall be rubberized truck tires cut to uniform size pads, in stand-out thicknesses of 9”, 10-1/2” or 12”, punched to receive 3/4” steel tie rods.
- All bumpers are closed with two 1/4” steel formed angles under approximately 1,500 lbs of pressure. 1/4” flat plates may be substituted for one or both angles.
- Anchor leg of angle extends a minimum of 3” beyond the rubber surface at either end and contains two or three 13/16” anchor bolt holes as required. (Anchor bolts are supplied separately). Finish for exposed metal parts is either chrome aluminum lead-free enamel, or hot-dipped galvanized.

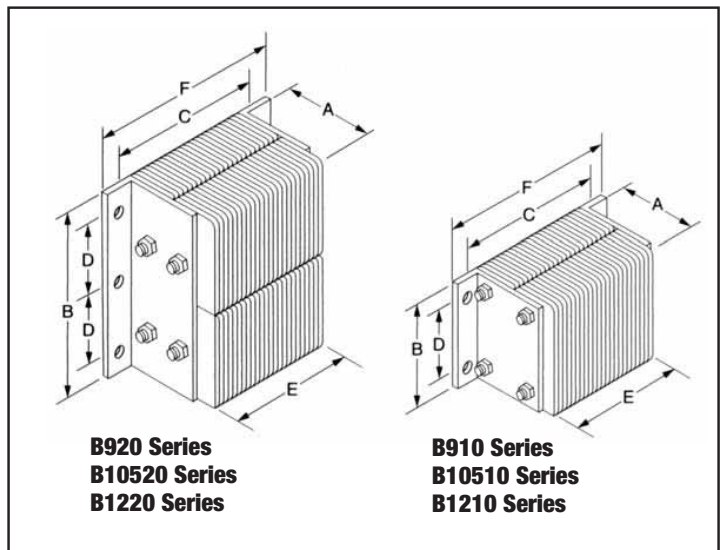

Model	Projection x Height x Bolt Hole Centers (Length) (A x B x C) Size	D Vertical Bolt Hole Centers	E Rubber Length	F Overall Length	Wt. lbs.
B910-14	9" x 10" x 14"	6"	10"	16"	63
B910-24	9" x 10" x 24"	6"	20"	26"	98
B910-36-A3*	9" x 10" x 36"	6"	32"	38"	152
B920-11	9" x 20" x 11"	6"	7"	13"	103
B10510-14	10-1/2" x 10" x 14"	6"	10"	16"	71
B10510-24	10-1/2" x 10" x 24"	6"	20"	26"	109
B10510-36-A3*	10-1/2" x 10" x 36"	6"	32"	38"	167
B10520-11	10-1/2" x 20" x 14"	6"	7"	13"	109
B1210-14	12" x 10" x 14"	6"	10"	16"	76
B1210-24	12" x 10" x 24"	6"	20"	26"	120
B1210-36-A3*	12" x 10" x 36"	6"	32"	38"	195
B11210-11	12" x 20" x 11"	6"	7"	13"	134

*Center anchorage device recommended for 36" long bumpers. A3 standard order; otherwise specified. See illustration on page 7.

MOLDED DOCK BUMPERS

Model B Series

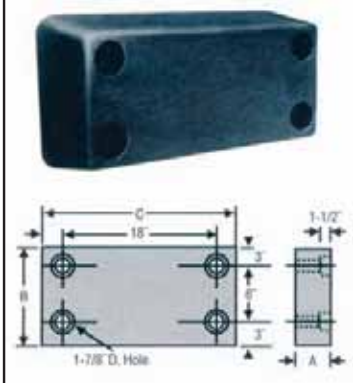

Model M-30

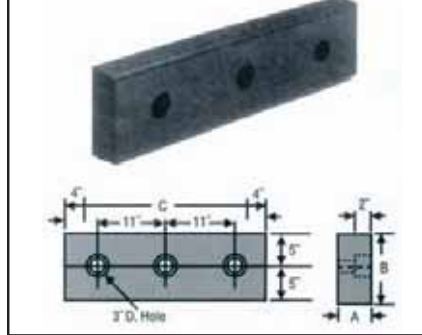

MATERIAL/THICKNESS

- Manufactured from fiber reinforced prime rubber containing nylon and polyester.
- Comes in models varying in thickness from 2" to 6".
- All bumpers have impact recovery (ASTM 1170) of 95% with a durometer reading of 80 plus or minus 5.
- Tensile strength: 950-1505 PSI
- All models have pre-drilled, countersunk mounting holes for easy installation, and are drilled to accept 3/4" anchor bolts.

INSTALLATION

- Installation is easy—3/4" anchor bolts are mounted through pre-drilled holes into dock.

SPECIFICATIONS

- Molded in one piece of all new nylon and new polyester reinforced rubber.
- Bumper to have a durometer reading of 80 plus or minus 5, tensile strength of 950-1050 PSI, and an impact recovery (ASTM 1170) of 95%.

USES/APPLICATIONS

- Perfect protection for any low traffic truck dock.
- In-plant wall protection from forklifts and other material handling vehicles.

FEATURES

- Makes for a clean, neat, attractive dock area.
- Molded in one piece.
- Will not warp, rust, rot or harden.
- Compact size.
- Spectra-Shield Dock Bumper face constructed of Ultra High Molecular Weight (UHMW) polyethylene recessed into reinforced molded rubber. Call for information and specifications.

BENEFITS

- Unique design and construction achieves high impact resistance and long life.
- Immune to all weather conditions.
- Maintenance-free.
- Offers the correct amount of resiliency to absorb pressure and impact shock without damage to truck or dock.
- One year warranty.

Spectra Shield

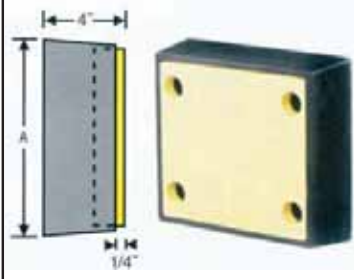

Model T

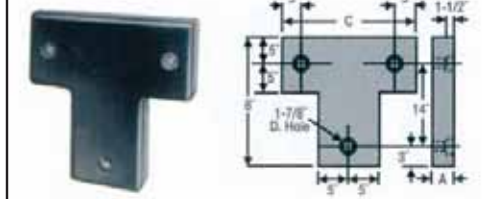

Model L

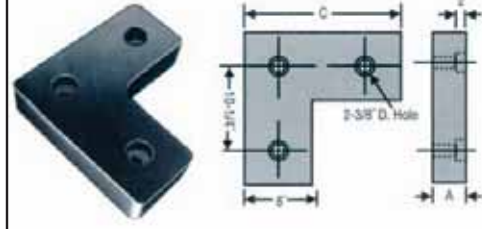

Model M-18

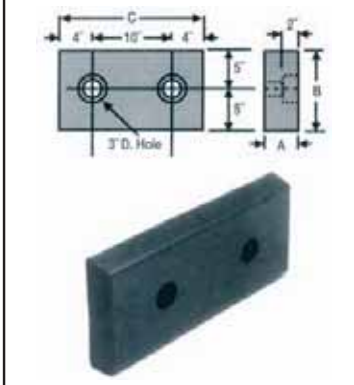

Model R

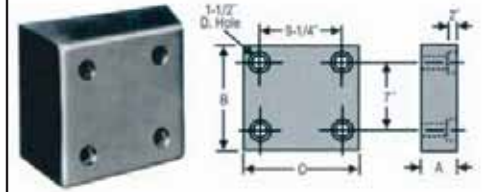

Model	A Thickness	B Height	C Width	Bolt Size	No. of Bolts	Wt. lbs.
T	3"	22"	22"	3/4" x 4"	3	35
L	4"	18"	18"	3/4" x 6"	3	33
R	4"	12"	13"	3/4" x 6"	4	23
M-18	4"	10"	18"	3/4" x 6"	2	27
Spectra Shield SS1213	4"	13"	12"	3/4" x 6"	4	24
B	3"	12"	24"	3/4" x 4"	4	29
BB	4"	12"	24"	3/4" x 6"	4	38
BBB*	6"	12"	24"	3/4" x 6"	4	67
M-30	4"	10"	30"	3/4" x 6"	3	43
DB-13	4"	10"	13"	5" x 6"	2	18

WHEEL CHOCKS

MODEL 88-8 *PREMIUM*

- Extra heavy-duty.
- Laminated rubber pads assembled on 3/4" bolts and compressed between 1/4" steel plates.
- Contoured to fit tire.
- Fully meets OSHA requirements.
- Reversible.
- 5 year warranty.

NOTE: Also available with gripper cleats for better traction in snow, ice, dirt and mud.

MODEL 68-9

- Molded from tough fiber-reinforced rubber compound.
- Well suited for trailer trucks and other heavy equipment.
- One year warranty.

MODEL 811-7

- Light weight yet heavy duty.
- Molded urethane chock contoured to fit truck tires.
- Designed to grip both the tire and the pavement.
- Will not harm macadam.
- One year warranty.

MODEL SC-8

- Light weight, non-sparking extruding aluminum.
- Surface gripping teeth on underside.
- One year warranty.

Other models available. Please call for information and pricing on models not listed.



Model 88-8



Model 68-9



Model 68-9 OR



Model 811-7



Model SC-8



SAFETY ACCESSORIES

- Safety sign for wall mounting reminds drivers and dock personnel to chock vehicle wheels.
- Chain and bracket secures wheel chock to wall and provides convenient storage location.

OSHA SPECIFIES:

1910.178 (k) Trucks and railroad cars. (1) The brakes of highway trucks shall be set and wheel chocks placed under the rear wheels to prevent the trucks from rolling while they are boarded with powered industrial trucks.

Model	Width	Height	Length	Wt. lbs.	Color
88-8	8"	8"	8"	15	Black
68-9	8"	5-3/4"	9"	9	Black
68-9 OR	8"	5-3/4"	9"	11	Orange
811-7	11-3/8"	8-1/4"	7-5/8"	6-1/2	Orange
SC-8	11-5/8"	8"	7"	6-1/4	Aluminum

NOTE: Custom extruded chocks and wedges available upon request.

PARKING BLOCKS/SPEED BUMPS

PARKING BLOCK BENEFITS

- Easy, one-person installation.
- Maintenance free.
- Maintains attractive colorful appearance year-after-year.

MATERIAL

- 100% recycled, heavy-duty plastic.

PARKING BLOCK FEATURES

- Made of 100% recycled, heavy-duty plastic.
- Available in three colors: safety yellow, handicap blue and gray.
- Light weight, yet durable.
- Optional hardware available.

SPEED BUMP BENEFITS

- 10 mile-per-hour design helps protect people and property.
- Easily movable for changing traffic patterns or snow plowing.
- Easy, one-person installation and relocation.
- Maintenance free.
- Less costly than competitive alternatives.

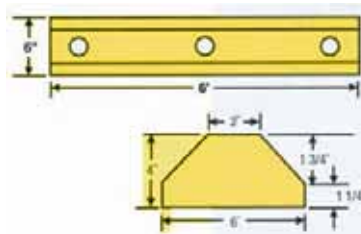

MATERIAL

- 100% recycled, heavy-duty plastic.

BENEFITS

- 5 year warranty

SPEED BUMPS FEATURES

- Made of 100% recycled, heavy-duty plastic.
- Molded in safety yellow color.
- Light weight, yet indestructible.
- Durable, built for long-lasting service.
- Hardware included.

Model	Color	Width	Height	Length	Weight lbs.
RPC-366-BL	Blue	6"	4"	6'	35
RPC-366-GY	Gray	6"	4"	6'	35
RPC-366-YE	Safety Yellow	6"	4"	6'	35

Model	Width	Height	Length	Weight lbs.
HPR-0072	10"	2"	6'	35

WHEELRISERS & PLATFORMS

STEEL AND ALUMINUM WHEELRISERS (SWR and AWR)

- Eliminates unsafe, below dock loading conditions
- Reduces damage to loading equipment
- Heights up to 12"

Wheelrisers allow trailers to be positioned properly above dock for more efficient loading. Widths of 18" to 24". Lengths to accommodate both single, dual, or tandem axle trailers. Wheelrisers can be portable or permanently positioned. Custom sizes are available.

STEEL (SWR)

- Tabs for anchoring

ALUMINUM (AWR)

- Have hand holds for easy moving.

STEEL PLATFORMS (SP)

Place a steel platform in front of any railcar for 90 degree loading/unloading. Place it in the open and service as many as three trailer positions at the same time. Steel platform affords 90 degree turnability for safe forklift maneuvering. Steel platforms are a fast, economical way to expand your dock area and increase freight handling capabilities without the expense of site or concrete work. Steel platforms can easily be relocated to other areas of your yard where a freestanding loading dock may be needed. This means more trucks or railcars can be serviced while freeing up other critical dock doors. Optional adjustable, telescoping legs of 44" to 55" allow elevations to meet most dock height requirements. For remote areas a steel platform along with a yardramp can serve as a satellite unloading area.

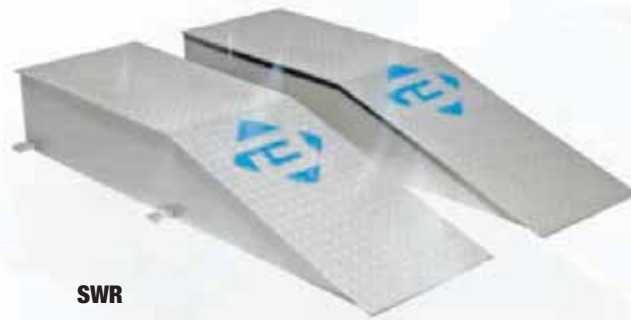

SWR

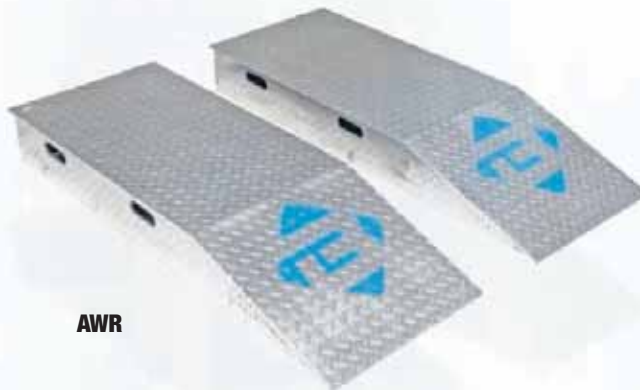

AWR



SP

DOCKLEVELERS

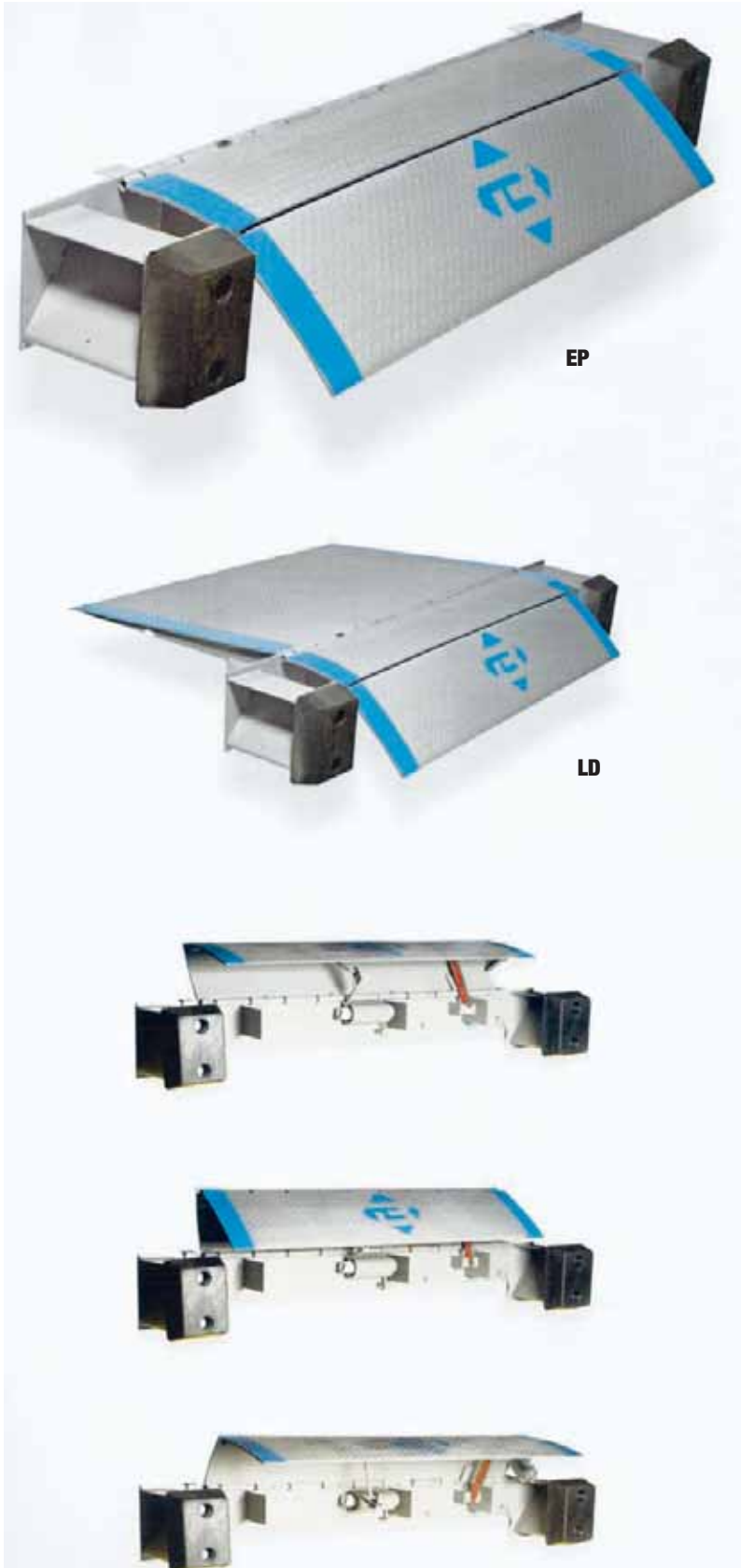

EP

LD

EDGE-OF-DOCKLEVELER (EP)

- Capacities from 20,000 to 25,000 pounds
- Widths of 66", 72" & 78"
- Automatically returns to stored position when truck leaves
- Self-storing handle
- Refrigerated lip optional
- Bumper and bumper blocks are included
- Steel faced bumpers available

LO-DOCKLEVELER (LD)

- Raises edge-of-docklevelers to proper working height
- Completely assembled; no site welding required

Now without expensive dock alterations, you can raise the height of your present dock as much as 11". Lo-docklevelers can easily be installed on any concrete dock without welding or modifications. Refrigerated lip is optional. Complete technical information and installation instructions are available upon request. *Edge-of-dockleveler is designed to have a working range of 5" above and 5" below dock. Because of gradability problems docklevelers are not recommended for use with pallet jacks or stackers.*

FAST AND EASY OPERATION

Fast and easy to operate, this edge of dockleveler is positioned by lifting a self-storing handle and pulling the handle to the dock floor. The latch assembly activates the lip forward to the floor of the trailer as the handle is lifted. When released, the handle automatically returns to a stored position. The optimum dock height for conventional trailers is 51", while the proper dock height for refrigerated equipment is 55". Refrigerated lip is optional. Widths of 66", 72" and 78" are available.

LEVELER ACCESSORIES & TRACK GUARDS

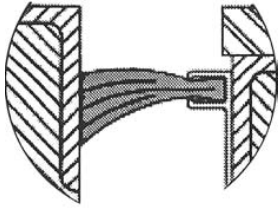

Rear seal is designed with super foam construction for lifetime use.

Leveler sealing kits are necessary for keeping cold air and insects out of your warehouse. These inexpensive kits are easy to install and durable enough to last for years!

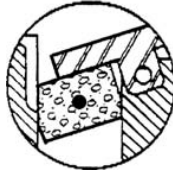

Tough industrial strength brush seals can be mechanically mounted, or welded on to your surface.

Finish it right! Complete the seal!

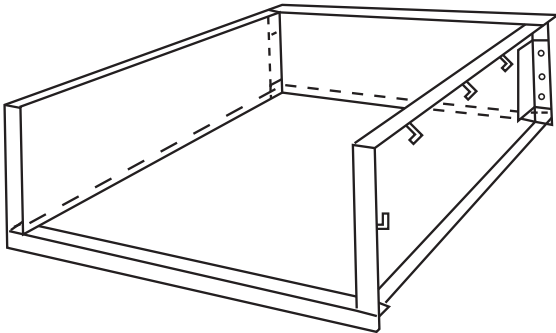

PIT LEVELER EASY PAN

The Easy Pan pit leveler forming kit lives up to its name. This unit is set down into an oversized rough pit. The concrete is poured around the pan and the result is a professional, accurate preparation for leveler installation.

DOOR TRACK PROTECTORS

Standing Guard Track Protectors are designed to eliminate costly damage to overhead door tracks that can be caused by forklifts, cars, trucks, and negligent acts. Doors with damaged tracks can be costly by inhibiting operation of the doors and interfering with the loading and unloading of products and/or equipment. Sets can be shipped via UPS.

Easy Installation—Large Savings for Minimal Investment—Reduces Insurance Claims

**Built for the Protection of Overhead Door Tracks!
Designed to fit any size or shape of track!**

- 40" High
- 6" fabricated channel made from 1/4" thick A-36 hot roll pickled and oiled steel
- Welded to a 1/4" thick 6" x 10" plate made from the same material
- Plate has (4) 5/8" diameter holes punched 3/4" from edges
- All edges are de-burred prior to being painted using Sherwin Williams safety yellow epoxy paint
- (8) 1/2" x 4-1/4" wedge anchors are included with each set.

ALUMINUM DOCKBOARDS

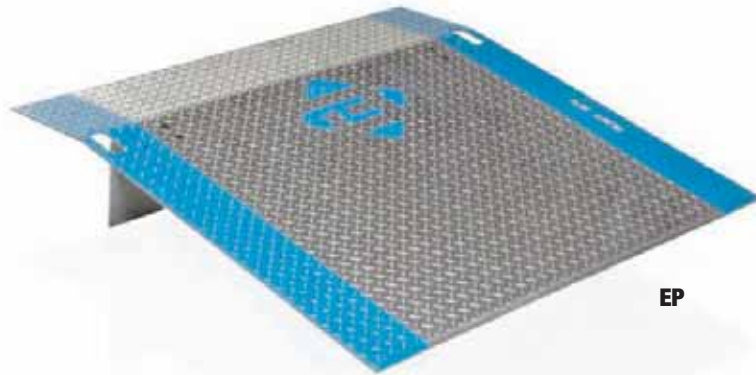

EP

Aluminum products are ideal for low to medium volume dock loading application.

ALUMINUM DOCKPLATE (A-B)

- Recommended for nonpowered loading applications
- Available in two capacity ranges
- Low-cost solution to light activity applications
- Bolt-on steel legs for securing position between the dock and the trailer

Lip bend is 11°. Standard lip length for conventional trailers is 11", option of 14" for refrigerated applications. Aluminum dockplates are designed to work well with pallet trucks or other nonpowered loading equipment. Machine beveled deck edges allow for smooth transition. Wide range of sizes available.

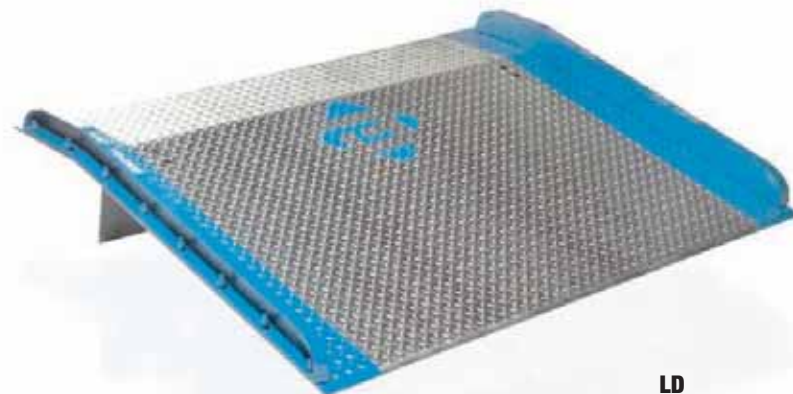

LD

ALUMINUM DOCKBOARD (AC-BC)

- Capacities from 10,000 to 15,000 pounds
- Full-length structural steel bolt-on curbs

Steel curbs are bolted to the aluminum diamond pattern plate for increased strength, and to help prevent runoff. Locking legs provide secure positioning. Lip bend is 11°. Standard lip length for conventional trailers is 11", option of 14" for refrigerated applications. Widths from 60" to 72", and lengths from 36" to 96".



LD

OPTIONS FOR PLATES AND BOLT-ON CURB BOARDS

EZ-Roll

- One person positioning without the use of a forklift
- Telescoping/out of way while board in use

Lifting Chains

- Positioning of board by forklift

Manufactured and tested in compliance with ANSI Standard MH30.2

STEEL DOCKBOARDS

Fully welded steel dockboards provide a safe ramp for powered vehicle application. Selecting the proper product for your application will improve product life, safety, and loading efficiency.

STEEL DOCKBOARD (SC)

- Steel plate with welded steel curbs
- Lifting chains included
- Capacity 10,000 and 13,000 pounds

This steel dockboard with welded steel curbs and locking legs is designed for 3,000 and 4,000 pound capacity forklift use in light use applications. Lifting chains are included. Width of 60" and 72". Lengths from 36" to 72".



SC

STEEL DOCKBOARD (T)

- All-welded steel construction
- Capacities from 15,000 to 40,000 pounds
- Two four-hole pin pockets placed on each edge for flexible positioning
- Fold-down lifting loops
- Double-bend design

This heavy-duty steel dockboard is held in position using two 1" stress-proof steel pins. When properly placed in the side pocket location holes, these pins hold the dockboard firmly in place guarding against slippage. Simply select the proper pin hole location for use with conventional, refrigerated, or container trailer, or for below dock conditions. Width from 60" to 96".

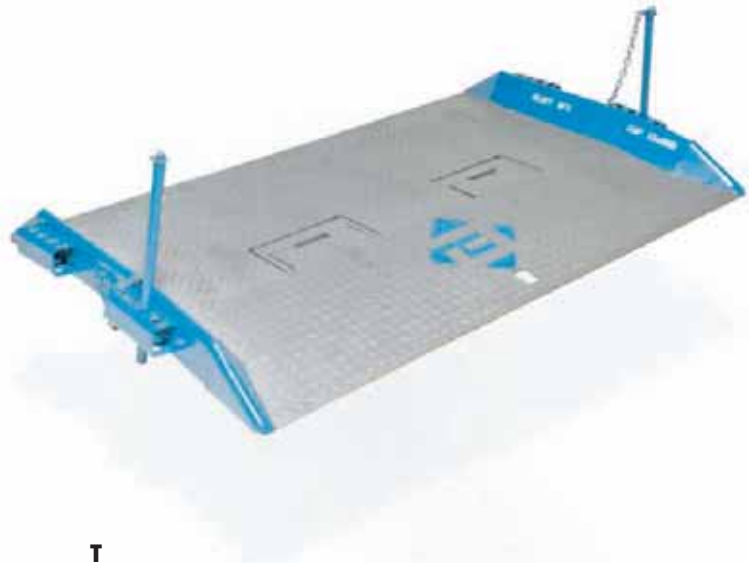

T

STEEL DOCKBOARD (TFL)

Same basic design as the "T" dockboard, but uses locking legs in lieu of steel pins.



TFL

STEEL DOCKBOARD (TNB)

Single-bend design utilizes the lifting chain and full width locking legs.

TFL and TNB designs are not recommended for below dock loading.

TNB



Manufactured and tested in compliance with ANSI Standard MH30.2

RED PIN STEEL DOCKBOARDS

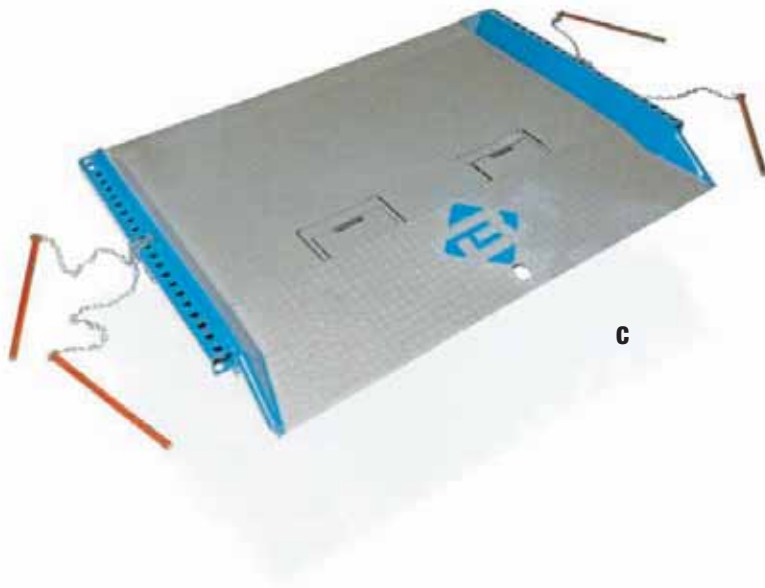

RED PIN STEEL DOCKBOARD (C)

- For difficult trailer-to-dock positions
- Dual-pin locking system
- All-welded steel construction
- Capacities from 15,000 to 40,000 pounds

The red pin dockboard utilizes full length side pockets along with two locking pins for each side. These pins provide safe loading conditions for container and park-out applications. Widths from 60" to 96". Lengths from 48" to 120".

RAILBOARDS



RAILBOARD (R)

- All-welded steel construction
- Capacities from 15,000 to 90,000 pounds
- Rectangular or flared design
- Box understructure for strength and safety
- Heavy-duty locking rings for safe, secure positioning
- Lifting loops fold flat into recessed pockets

Railboards are designed for use on all types of railway boxcars, including refrigerated and special cars for the lumber and the paper industries. First position the railboard next to the railcar. The locking ring will automatically secure the railboard against the dock. Box understructure bumpers fit around the car latches to protect door latch. All railboards are designed and built to match the specific dock conditions. The design is finalized by using information provided on a railboard worksheet.



LOCKING RING DESIGN

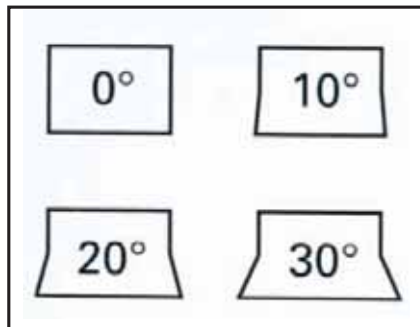

FLARE OPTIONS

DOCKBOARD SELECTION GUIDE

Selections should consider the extremes rather than averages. All trucks need to be loaded or unloaded, not just the average ones.

CAPACITY

PLATES

- Weight of equipment and heaviest load

BOARDS

- See chart
- Capacity rated for single-shift operation at a 3 mile per hour maximum rate of travel.
- Stackers and other narrow aisle loaders should not be used on a dockboard.
- Paper roll clamp and multi-shift loading add 5,000 pounds to the board capacity.

CAPACITY SELECTION CHART		
4-Wheel Forklift	3-Wheel Forklift	Board Capacity
2,000 – 3,000	2,000	10,000
3,000 – 4,000	2,500	13,000
5,000	3,000 – 3,500	15,000
5,000 – 6,000	4,000 – 5,000	20,000

LENGTH

To determine the proper length of a dockboard/plate, three items are required:

- Dock height (D)
- Height of highest truck (T)
- Gradability of loading equipment used

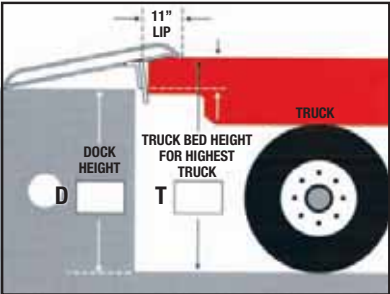

MAXIMUM TRAILER HEIGHT SERVED	
Freight Line Trailers	46" - 56"
Flatbed Trailers	50" - 60"+
Bob Tail Trucks	46" - 48"
Containers	56" - 62"
Reefer Trailers	50" - 60"

WIDTH

Bluff recommends a minimum product width of 12" to 18" wider than the overall width of the vehicle or pallet used. For improved end loading efficiency, you may consider increasing board width, as shown in diagram.

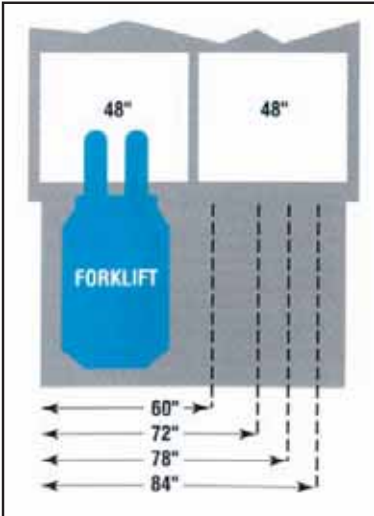

All railboard applications are factory quoted upon receipt of a fully completed railboard worksheet.

WALKRAMPS

WALKRAMPS

- Twin-tooth deck for better traction when traveling in either direction
- Strong, lightweight aluminum construction makes ramps easily portable and convenient
- All apron models complete with 8" apron; 3-1/4" position stop; safety chains
- All hook models complete with two heavy duty safety hooks

NOTE: Walkramps are not made for powered equipment or pallet jack use. Walkramps are intended for foot traffic use only.

HOOK MODEL



HOOK MODEL SPECIFICATIONS	
Nominal Lengths	3' - 16'
Actual Length	39" - 192"
Height Range	13" - 66"
Capacity Range	500 - 1,500 lbs.
2900 Series Weight Range	33 - 140 lbs.
3900 Series Weight Range	41 - 172 lbs.
Heavy-Duty Safety Hooks	2

APRON MODEL SPECIFICATIONS	
Nominal Lengths	3' - 16'
Actual Length	36" - 189"
Height Range	9" - 61"
Capacity Range	500 - 1,500 lbs.
2900 Series Weight Range	36 - 147 lbs.
3900 Series Weight Range	43 - 176 lbs.
Apron Size	8"
Position Stop Length	3.25"
Safety Chains	36"

APRON MODEL



MODULAR DOCK LIGHTS

(Shipped in Multiple Cartons)

Create your own dock light fixture...

Order the dock arm, light head or fan head individually!

LIGHT HEADS

Note: All modular Dock Light components are UL/C-UL Listed.

Modular Lights

- 18" long, 18/3 conductor cord plugs into electrical junction box on arm
- On/Off switch & wire guard included with each light head
- Bulb included with all light heads except DKL-INC
- All shades are adjustable up to 300°

Model	Light head Type	Max. Watts	Max. Lumens	Avg. Bulb Life (Hrs.)	Ship Weight
DKL-INC	Incandescent	200	3,700	2,000	5 lbs.
DKL-QH	Quartz Halogen	500	11,000	2,000	8 lbs.
DKL-SQH	Sensor Quartz	500	11,000	2,000	8 lbs.
DKL-MH	Metal Halide	100	9,000	15,000	10 lbs.
DKL-HPS	H.P. Sodium	50	4,000	24,000	7 lbs.
DKL-FL	Fluorescent	55	3,000	10,000	6 lbs.

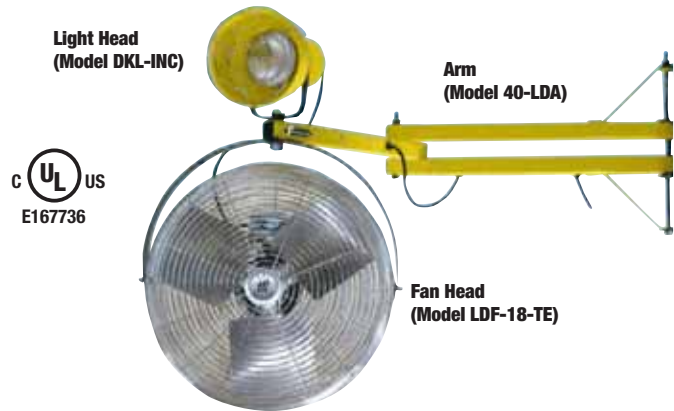

c US
E167736



INC

DKL-INC

QH

DKL-QH

SQH

DKL-SQH

MH

DKL-MH

HPS

DKL-HPS

FL

DKL-FL



Model: DKL-40VA-ARM
40" Arm

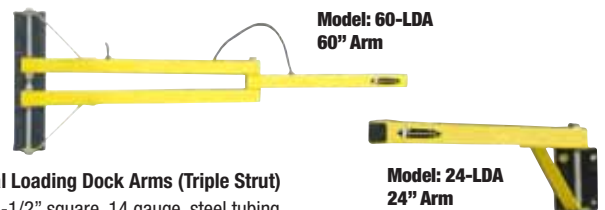

Model: 60-LDA
60" Arm

Model: 24-LDA
24" Arm

ARMS

Vertical Adjustment Loading Dock Arms (Dual Strut)

- 1-1/2" square, 14 gauge, steel tubing
- One or two piece tubing assembly
- The outer arm on 40" & 60" arms will swing 300° in horizontal plane & 210° in the vertical plane
- 3" x 5" x 3/16" mounting plate attaches with four (4) 3/8" bolts
- 5' long, 18/3 SJTW conductor cord and NEMA 5-15 grounded plug

Model Number	Arm Length	Shipping Weight
DKL-40VA-ARM	40"	18 lbs.
DKL-60VA-ARM	60"	24 lbs.

Dual Loading Dock Arms (Triple Strut)

- 1-1/2" square, 14 gauge, steel tubing
- Three (3) piece tubing assembly
- No vertical adjustment, horizontal positioning only (up to 300°)
- 3" x 5" x 3/16" mounting plate attaches with four (4) 3/8" bolts
- 5' long, 18/3 SJTW conductor cord and NEMA 5-15 grounded plug and two (2) outlet receptacles included

Model Number	Arm Length	Shipping Weight
24-LDA	24"	11 lbs.
40-LDA	40"	18 lbs.
60-LDA	60"	24 lbs.

FAN HEAD

Modular Fan

- 18" high velocity circulator, with 3-speed, 1/8 HP, 115V, 1phase permanently lubricated, totally enclosed, PSC motor
- Modular fan plugs into electrical outlet on arm
- Chrome plated metal guards
- Aluminum blades



18" Dock Fan Head Assembly
Model # LDF-18-TE

Model Number	CFM			Amps High	Ship Weight
	High	Med	Low		
LDF-18-TE	5750	4700	3200	2.2	20 lbs.

FULLY ASSEMBLED LOADING DOCK LIGHTS

(Shipped in One Carton)

METAL HALIDE

New! "Energy Efficient"

Dock arm made of 1-1/2" square steel tubing



UL US
E167736

40" Dock Arm Dimensions - MH Series

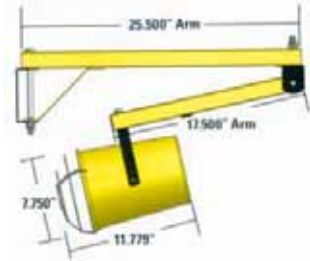

Metal Halide					
Arm Length	# of Arms	Model	Max. Watts	Lamp Included	Weight
24"	1	DKL-24-MH-A	100	Yes	13 lbs.
40"	2	DKL-40VA-MH-A	100	Yes	17 lbs.
60"	2	DKL-60VA-MH-A	100	Yes	21 lbs.

QUARTZ HALOGEN

Weatherproof aluminum die-cast light head with wire guard, handle, protective lens and integrated ON/OFF switch



24" Dock Arm Dimensions - QH Series

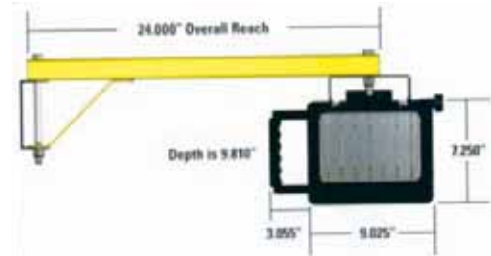

Dock arm made of 1-1/2" square steel tubing

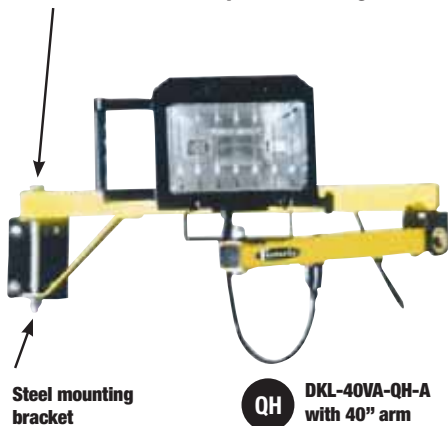

Quartz Halogen and Sensor Quartz					
Arm Length	# of Arms	Model	Max. Watts	Lamp Included	Weight
24"	1	DKL-24-QH-A	500	Yes	11 lbs.
40"	2	DKL-40VA-QH-A	500	Yes	15 lbs.
40"	2	DKL-40VA-SQH-A	500	Yes	19 lbs.
60"	2	DKL-60VA-QH-A	500	Yes	18 lbs.

SOH DKL-40VA-SQH-A with 40" arm

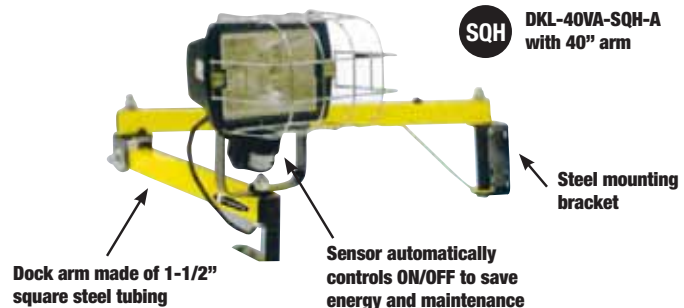

UL US
E167736

What Light Source Meets Your Needs?

Reference this coding system throughout the lighting section:

INC Incandescent	QH Quartz Halogen	SQH Sensor Quartz Halogen
MH Metal Halide	HPS High Pressure Sodium	FL Fluorescent

While dock lights effectively improve visibility within the trailer allowing for greater efficiency, a fan fixture can aid in ventilation, thus combating the fatigue caused by heat and forklift fumes. More efficiency, greater safety and less fatigue can all add up to a better bottom line for you.

Light Selection Chart & Illumination Levels						
Description	Light Source Type					
	Incandescent	Quartz Halogen	High Pressure Sodium	Metal Halide	Fluorescent	
Max Wattage	300	500	50	100	55	
Max Lumens	3,700	11,000	4,000	9,000	3,000	
Avg. Bulb Life (hrs.)	2,000	2,000	24,000	15,000	10,000	
Bulb Included	No	Yes	Yes	Yes	Yes	
Light Source Illumination Levels						
Measured Footcandles & Distance from Light Source (inside trailer)	10 ft.	15	28	85	142	9
	20 ft.	5	14	25	55	3
	30 ft.	3	8	11	18	2
	40 ft.	2	5	8	9	-

DOCK LIGHT PERFORMANCE TESTING

We measured light levels (in footcandles) inside a 8' x 9' x 53' trailer with a wooden floor and ceiling and white fiberglass walls. A matrix of nine measurements were taken at five work plains inside the trailer. Averages were figured along the center work plane of the trailer.

These charts measure the overall quality of truck trailer illumination from a selection of light sources. Many other factors such as: cost of energy, safety, UL Listing, availability of fixtures, cost of labor and replacement lamps should figure into your final decision.

Light Source and Color Characteristics	10 ft.	20 ft.	30 ft.	40 ft.	50 ft.
100W Metal Halide (Bright White)	142	55	18	9	7
500W Quartz Halogen (Bright White)	28	14	8	5	3
50W HPS (Dull Yellow/Orange, Low CR)	85	25	11	8	4
300W Incandescent (Off-White)	15	5	3	2	*
55W Fluorescent (Bright White)	9	3	2	*	*

* Represents light levels that are generally less than adequate for modern loading conditions.

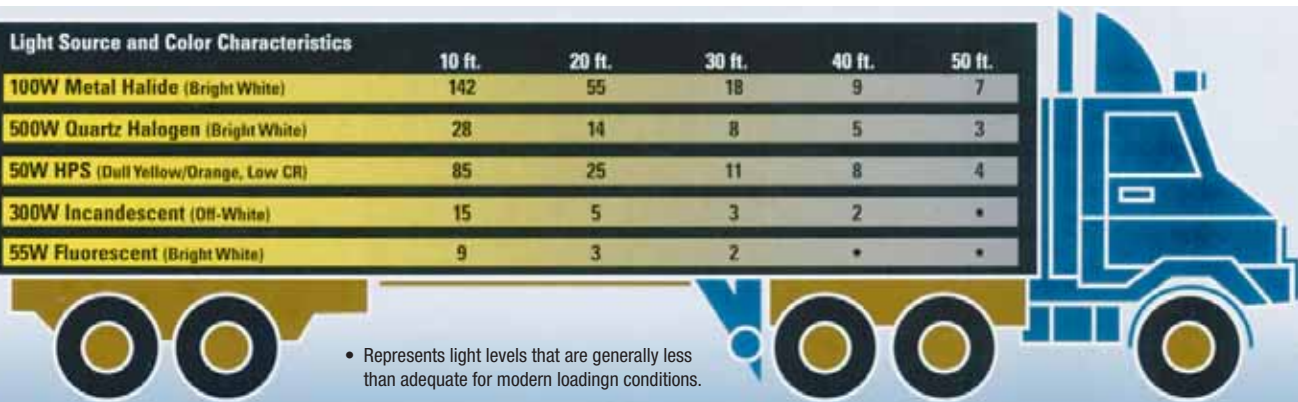

NOTE: Footcandles and Distance from Light-Source Measured from within a 53 ft. Wooden and Fiberglass Trailer

TRI-LITE STOP & GO SIGNAL SYSTEM

The Stop & Go Signaling System Alerts Truck Drivers and Loading Dock Personnel to the Safety Status of Docked or Docking Trucks...

The SG30 System utilizes two units—one outside of the loading dock and one located on the inside. The system is controlled by a toggle switch mounted on the inside light. (Remote switching is possible.) When the outside light is flashing red the inside light is green. This tells drivers not to move the truck and indicates that the loading and unloading may proceed. When the toggle is flipped, the red light inside warns dock workers to stay out of the trailer, and green tells the driver he is free to move the vehicle.

The SG10 is available for applications where opposing signals are not required. Ideal for installations utilizing external controllers such as drive thru indicators and for OEM applications.

SUPER BRIGHT LED SIGNALS

- Reduce energy costs by 90% compared to conventional incandescent lights
- No filament means long life
- Require no maintenance
- Three year limited warranty on LED
- Loading dock warning signs available

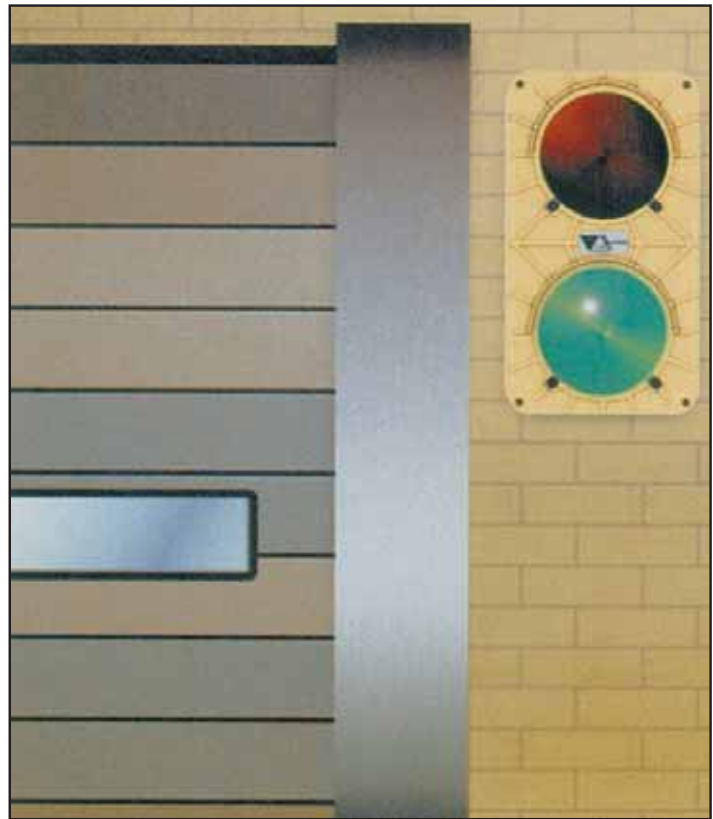

TECHNICAL SPECIFICATIONS

Housing	Safety Yellow or Black Polypropylene
Power Source	12 or 24 volt DC operation or 115 volt AC operation
Lens diameter	4 1/2"
Dimensions	11 1/2" H x 6 1/2" W x 3 1/2" D
Shipping weight	2 lbs. per unit

CONFIGURATIONS AVAILABLE

STOP & GO LIGHT SET (includes 1-SG10, 1-SG20)				STOP & GO LIGHT, WITH FLASHER AND SWITCH				STOP & GO LIGHT, NO FLASHER OR SWITCH*			
Item #	Style	Voltage	Amps	Item #	Style	Voltage	Amps	Item #	Style	Voltage	Amps
SG30-12RG	Incandescent	12v	4.34	SG20-12RG	Incandescent	12v	2.17	SG10-12RG	Incandescent	12v	2.17
SG30-12RG-LED	LED	12v	0.60	SG20-12RG-LED	LED	12v	0.30	SG10-12RG-LED	LED	12v	0.13
SG30-24RG	Incandescent	24v	2.20	SG20-24RG	Incandescent	24v	1.10	SG10-24RG	Incandescent	24v	1.10
SG30-24RG-LED	LED	24v	0.60	SG20-24RG-LED	LED	24v	0.30	SG10-24RG-LED	LED	24v	0.13
SG30-115RG	Incandescent	115v	0.42	SG20-115RG	Incandescent	115v	0.21	SG10-115RG	Incandescent	115v	0.21
SG30-115RG-LED	LED	115v	0.06	SG20-115RG-LED	LED	115v	0.03	SG10-115RG-LED	LED	115v	0.10

*Models and specifications subject to change

* Designed for use with SG20 or control panel with flasher
Incandescent models require flasher for proper operation.

STRIP DOORS & PVC MATERIAL



STRIP DOORS

Transparent Strip Doors are used in high traffic areas to effectively cut energy costs, save time, and promote safety. A series of flexible plastic strips permits rapid unrestricted passage, yet isolates noise, fumes, and loss of conditioned air.

- Exceptional Clarity
- Full Spec Material
- Made in the USA
- Save Energy
- Isolate Noise
- Keep Fumes Out!
- Keep Conditioned Air In

Save time and have your door--factory assembled!

PVC MATERIAL

Our material is non-yellowing and available in multiple weights and widths. A special tinted material is available to enclose welding areas. For food processors, cold storage and freezer doors, a non-toxic USDA accepted polar material should be specified.

Typical Strip Door Applications	Specifications		
	Thickness	Width	Overlap
Personnel Door For interior walk-through doors up to 7' height. Lightweight and inexpensive.	.040" .060"	6"	2"
For interior doors to 8' height. 9' height with full lap Not recommended for exterior opening.	.080"	8"	2" or Full
For interior doors up to 10' height. Not recommended for exterior opening.	.080"	12"	4" or Full
For minimum protection for exterior openings. Maximum 12' height.	.120"	12"	4"
For better protection for exterior openings to maximum 14' height. Also for better noise control.	.120"	12"	Full
For doors with heavy vehicular traffic. Somewhat difficult for personnel traffic.	.160"	16"	4" or 6"
For exterior doors with constant heavy-duty equipment. Best for sound control. Not recommended for constant personnel traffic.	.160"	16"	Full

- Smooth PVC strips
- Ribbed PVC strips
- Anti-static PVC strips
- Weld PVC strips
- USDA PVC strips

Material is available in Bulk Rolls or custom sizes!

Partial Overlap



Full Overlap

Strip overlap and width can be an important decision to make if you want an efficient door! Door height, weather conditions, and traffic should be a factor in your decision.

Added bonus — Get orange end pieces at no extra cost!

STRIP DOOR HARDWARE

USM

If you need a strip door that is a safe and consistent performer then you need our **Universal Steel Mount hardware system!**

Over the years manufacturers have come up with different ways to build PVC strip doors, but the efficiency, safety, and performance of the doors has not been addressed! Our hardware is Industrial Grade Steel, strong enough to last a lifetime, rounded mount covers give PVC strips a longer life, and the ease of installing make it the #1 choice in today's market. Safety and time is money in your pocket! Don't take a chance, order Today!

Universal Steel Mount can be mounted between jambs or on the face of your wall.

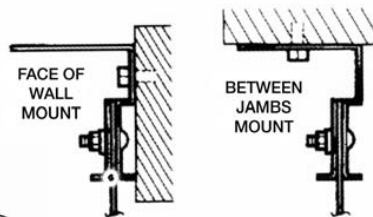
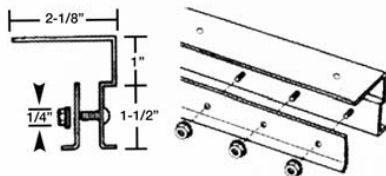

Cover plate and USM have rounded edges to keep strips from breaking. 1/4" x 1" studs are permanently fixed on 2" centers.

ROLLING STYLE MOUNT

Rolling Style doorways can be the convenient system for some warehouses and buildings. For a rolling door remember that wall space is needed for the door to roll across while in the open position.

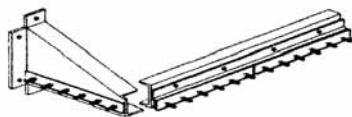
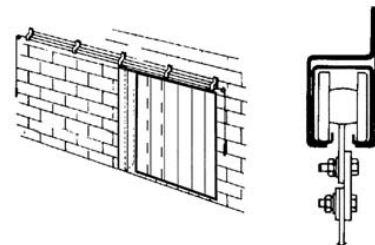

FRAME-IN-MOUNT

Frame-in-mounting styles are designed with PVC returns on both ends to seal edges tight! This system allows the strip door to free-span door tracks. It will not inhibit door operation and strip door is inside building when garage door is closed.

REMOVABLE MOUNT

Rotary's exclusive removable Mount is ideal for allowing your strip door to be used seasonally. Sometimes a strip door needs to be removed and stored and then re-hung at a later date. With the removable mounting system, the hardware needs to be attached just once to your building's surface, and then the Universal Steel Mount can be taken down over and over again without drilling new holes.

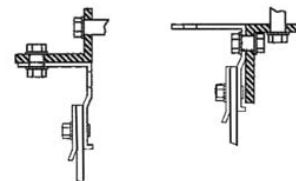

Storage can present a problem for PVC strips. Each strip is concave to make a perfect seal so it's important that if you re-hang a strip door that you put the strips back the way they are designed to work properly. Our Strip Door Storage rack can help. Just take down the Universal hardware with the strips already attached, and hang it up! Save money, time, and space by ordering an RPI Strip Door Storage Rack! Units hold up to three 6' sections.

COMPRESSION SEALS

Our compression dock seals provide a tight seal between the truck trailer and the loading dock opening.

We know that special dock seal designs are needed to accommodate different slopes and sizes of trailers. That's what makes our seals outlast our competitors! If you want the most clearance for forklift traffic and products, a tight seal for insulation and protection against fumes, dirt, dust, insects and other unwanted matter, then you have come to the right place. Our seals are designed to look good for years to come.

Rotary seals are custom-designed to fit loading dock applications for companies serviced by ALL types of trucks!

- Specially-designed ventilation holes and vent pockets provide fast air escape and recovery when units are compressed and decompressed by contact with trailer
- Special bonding of polyurethane foam to the frame make these seals durable long-lasting performers

OPTIONS

- Belting guards
- Bumper seals
- Wear shields
- Snow hoods
- Fire retardant material
- Custom logos
- Weather stripping

All units are equipped with yellow safety guide stripes to aid drivers in proper alignment of their trailer with the seal.



Loading Dock Design is a key factor to your choice of seal!

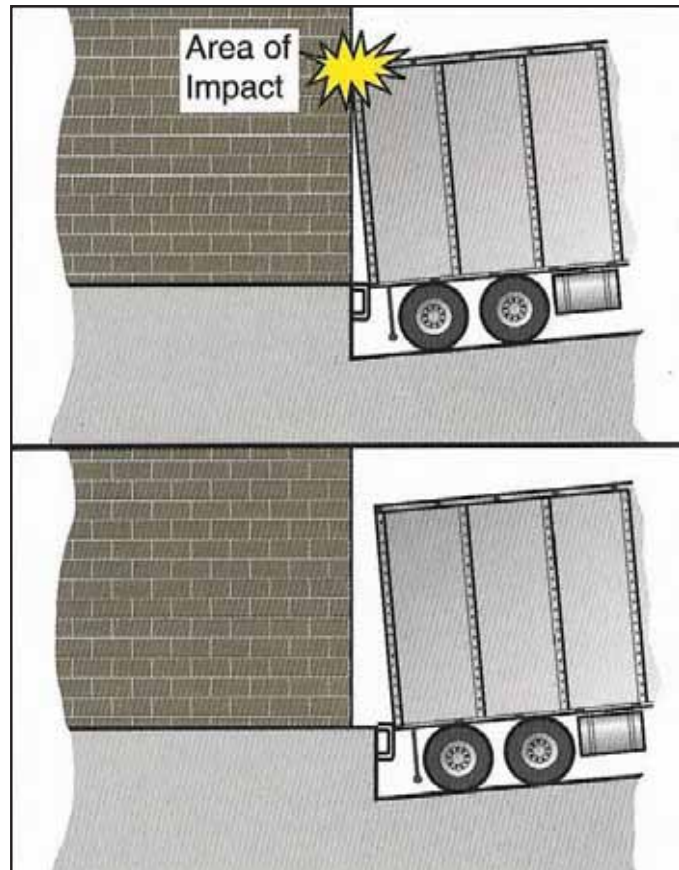

COMPRESSION SEAL DESIGNS

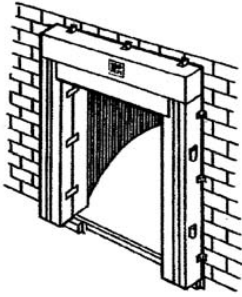

C8 THROUGH C21

Header pads with projections from 8" to 21" in 1" increments are available in various combinations of 22 oz. Vinyl; 40 oz. Duroprene; 16 oz. Hypalon; and 40 oz. Hypalon.

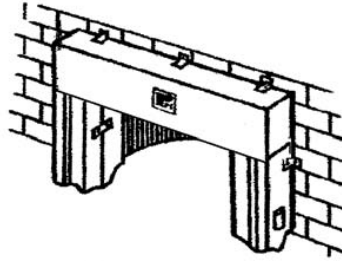

18" HEADER PAD

An 18" high head pad accommodates a greater range of trailer heights than the standard 12" high pad.

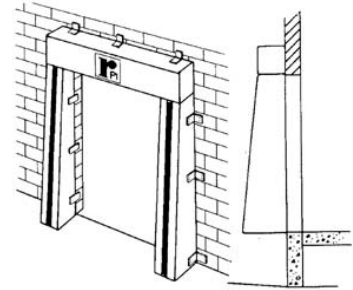

TAPERED COMPRESSION SEAL

Tapered compression seals are designed to match the angle, and form a tight seal with trailers backing up or down sloped drives. Prices are determined by the deepest dimension of the seal. Please consult the factory.

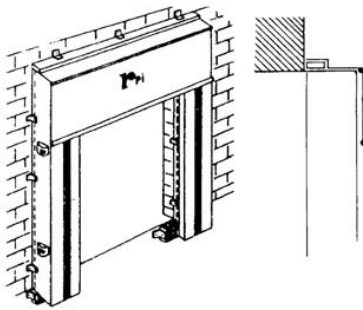

MC HEADER

The MC Header is an efficient practical design combined with the highest quality materials to seal extra high door openings. This header design is used to reduce door height openings 10' or higher.

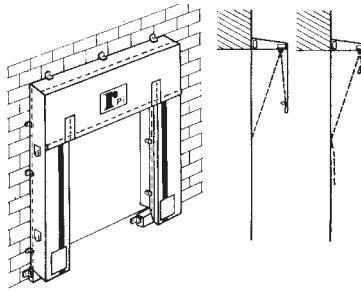

AC HEADER

The Adjustable Curtain Header is the recommended design to accommodate and gain full access to various heights of trailers. The simpler construction of a split, roll-up curtain by rope and pulley arrangement is less expensive and more serviceable than the adjustable foam filled header.

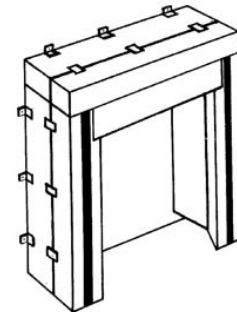

EXTENSIONS

We offer extensions for all compression seals including Z series. Wooden extensions are required when the seal protection is over 21". Made of construction grade painted lumber, extensions are vinyl-covered to match the seal at no extra cost.

WEDGE SHAPED PADS

A wedge style pad is available to fit 8' wide doors to reduce the opening without reducing the door size. The base of the pads is 9", wedged to 12" on the face. Custom wedges are available to fit any special situation.

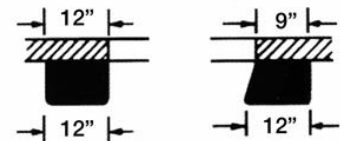

DOCK SURVEY

Information Needed for Ordering & Pricing

(Indicate Metal or Block Building)

Note: It is necessary for factory engineers to have complete dock survey information in order to determine the ideal unit for a given application.

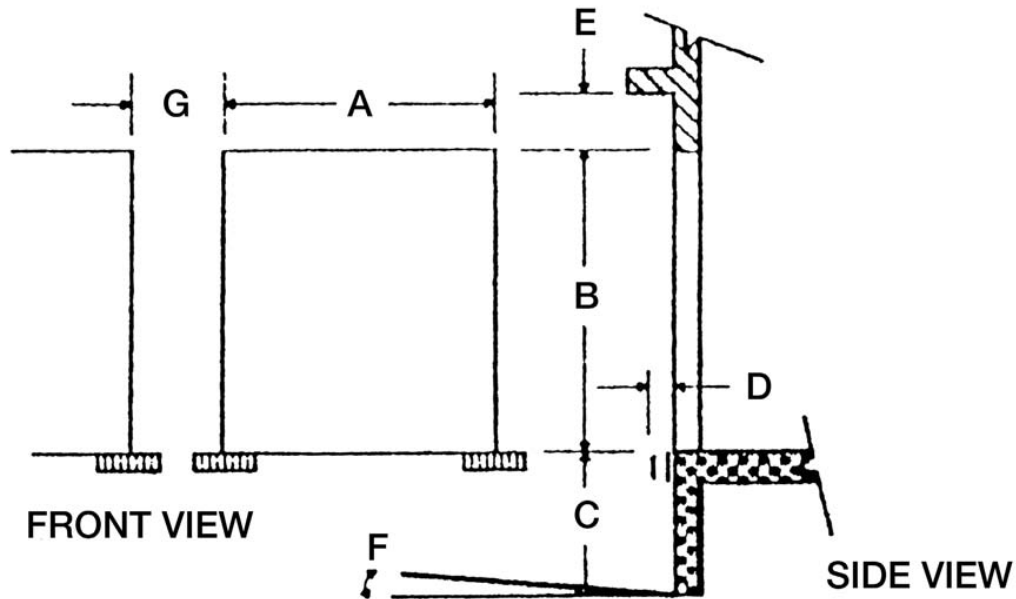

MEASUREMENTS

- A Opening Width _____
- B Opening Height _____
- C Dock Height _____
- D Bumper Protection _____
- E Top Clearance _____
- F Sloped Drive Angle _____
- G Side Clearance _____

SPECIFIC APPLICATION INFORMATION

- Range of Truck Height _____ to _____
- Range of Truck Width _____ to _____
- Require Full Access to Truck Height? Yes ___ No ___
- Require Full Access to Truck Width? Yes ___ No ___

HELPFUL FACTS ABOUT LOADING DOCKS

WHAT IS THE #1 CAUSE OF DISASTROUS LOADING DOCK DESIGN?

On almost a daily basis, we are seeing docks with sloped approaches toward the building and pit levelers. No part of the truck should ever be closer than four inches to the wall of the building. Standard pit levelers come with 4.5" bumpers for level driveway approach. There is zero tolerance for any decline or sloped approach toward the building. Backing the truck down toward the building causes the top of the truck to come closer to the building wall than the bottom.

If this is not addressed in the design, the solution can be extremely difficult, expensive, or even impossible depending on the severity of the slope. Replacing the standard 4.5" bumpers with thicker ones would be the most likely solution except that this reduces the amount of leveler lip extending into the truck, creating a safety and liability issue. A level truck approach is an obvious solution, but the existing site may not allow this or it may be costly. Also, changing the bumper protection after the fact will make other dock equipment, such as seals or shelters, incorrect for the application.

The proper solution can be accomplished by designing the dock area of the building with a wall setback or constructing the building with a concrete ledge even with the floor of the building that projects out several inches. Either design provides the needed space between the wall and the approaching vehicle in a decline situation. (See Figure 1)

For mild declines of 1%-3%, it is possible to add bumper projection and, if levelers are involved, use the 20" lip option adding 4" of lip projection to the standard leveler.

WHAT ARE THE MAIN FACTORS THAT NEED TO BE CONSIDERED WHEN DEALING WITH A SLOPED APPROACH TOWARD A LOADING DOCK?

It would be nice if there was an iron clad mathematical formula for determining the percentage or degree of grade and the minimum safe bumper projection and taper of dock seals or shelters, there are too many variables. If we are told that the approach rises x inches over y feet, it is almost never a constant slope. Rather, there is normally some flat area adjacent to the building (which helps a lot), then the drive can go up, flatten out, and maybe go up some more. This means that different trucks can come in at different angles. It is better to have the bumpers protruding out too far than not far enough.

Some equipment manufacturers refer to degrees of slope and

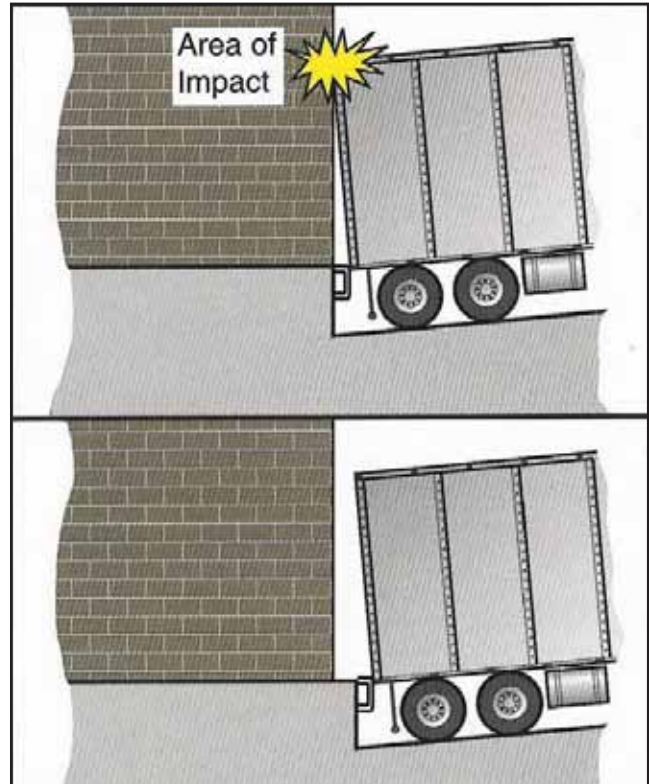

FIGURE 1

others refer to percent of grade. We prefer to work with percent of grade. It has been our experience that most customers calling in with the slope measured in degrees are feeding us numbers that are too high to be realistic or accurate. A chart comparing percent of grade to degrees is provided. (See Figure 2)

The percentage of grade is determined by dividing the height difference by the ramp length. As previously stated, the top of the truck needs to be at least four inches away from the wall, so the safe bumper projection is the percent of grade converted into inches plus four. For example, if the ramp rises 2' over 40', then there is a 5% grade so the recommended safe bumper projection is 9". Extra thick laminated dock bumpers are available in various projections up to twelve inches, but the best thing to do is to plan ahead and provide the extra concrete ledge as previously described.

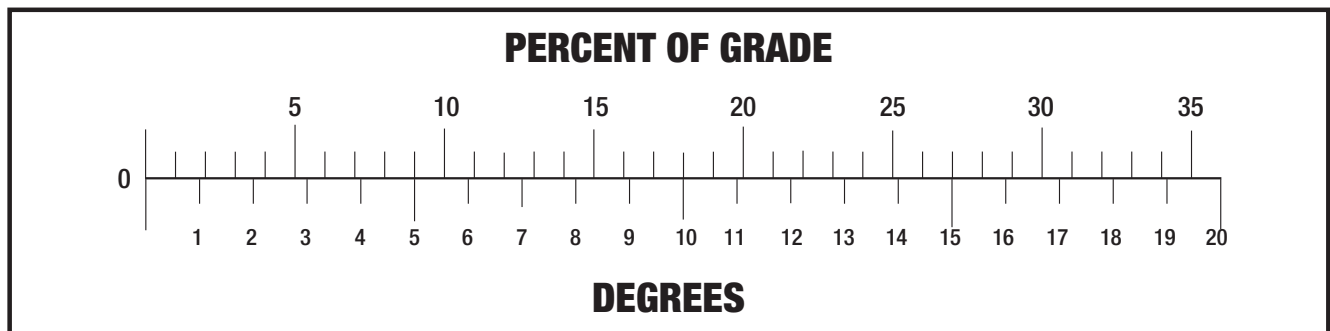

FIGURE 2

HELPFUL FACTS ABOUT LOADING DOCKS

WHAT IS THE IDEAL DOOR OPENING SIZE FOR A LOADING DOCK?

Again, there is no simple answer to what seems like a simple question. Many factors need to be taken into consideration: (1) whether the customer has a fleet of trucks that are all identical or if they are serviced by a range of common carriers, (2) the dock height and range or truck heights, and (3) the type of freight. For example, if the best possible seal was desired, and the trucks were 8' wide and 12'6" to 13'6" high, the dock height was 4', and full access to the truck opening was not required, the ideal opening size would be 7'6" x 8'6" using a seal. If the trucks were 8' or 8'6" wide and full access to the truck opening was required, then the ideal opening size would be 8 x 10 and a rigid shelter would be a better solution. In general, the larger the opening, the less efficient the dock will be in terms of energy consumption.

TO BE 100% SURE THAT THE DOCK WILL BE DONE CORRECTLY, WHAT DO I NEED TO KNOW?

The dock height is a critical dimension. Generally, a standard dock height is considered to be around 48", but several inches more or less is very common. A shorter dock height will raise the top of the truck in relation to the door opening and a deeper dock height will lower it. Forgetting to check the dock height can create problems such as a deep dock height causing the truck to not seal at the top or a shallow dock height causing the truck to hit a standard shelter too high and damage it.

The range of truck widths is another factor that needs to be considered. Most semi trailers are 8', but many of the newer ones are 8'6". On the other extreme, some smaller trucks are also used at docks in places such as bakeries, so they could be even less than 8' wide. Also, when smaller trucks are involved, it is common for them to have some sort of step or lift gate that causes the box of the truck that needs sealed to be even further away from the wall. When dealing with step type trucks, the only way to use a foam dock seal is if those are the trucks being used at the dock. Whenever both step trucks and non-step trucks are used at the same dock, a rigid shelter is the way to go.

Another special type of semi trailer is the high cube trailer. These are full height trailers that have bottoms low to the ground. They are often used by companies that have low density, lightweight products such as mattress or potato chip companies. Often, companies using this type of truck have special short dock heights of 18" to 24". Other times, they use ramps to raise the floor of the trailer up even with the floor of the building. The use of riser ramps at docks can cause many problems with dock seals and shelters, and the solution to this situation needs to be looked at carefully.

Another common problem encountered with loading docks is that sometimes people try to put too many openings in not enough space. Side room and head room is critical for the proper installation and performance of dock seals and shelters.

LOADING DOCK DESIGN CONSIDERATIONS

Designing the loading dock area of any given building would, at first glance, appear to be a simple task. However, just as other areas and components of a building are critical to its efficient function and use by the occupant, the loading dock must be properly designed for efficient movement of product over the dock. To achieve a proper dock design, the following items must receive thorough consideration:

- A. Truck movement to and from the dock. Can the building be positioned on the available site to meet local codes and also provide safe, efficient access for approaching trucks?
- B. Quantity of door openings
- C. Grade of truck approach (i.e., incline, decline, or level)
- D. Style of truck (i.e., tractor trailer {common carrier or captive fleet}, straight truck, step vans, trucks with hydraulic lifts, or package delivery vans).
- E. Truck restraint devices
- F. Number of trucks per door per day
- G. Method of loading (i.e., pallet jack, fork lift, unitized loads, conveyer, or hand loading)
- H. Weight, frequency, and speed of forklift
- I. Whether to use dock seals or shelters
- J. Dock height
- K. Dock leveler style

Another very prevalent problem is over compression. Many consider 12" projection seals and 4" projection bumpers to be standard. The problem with this is that the seals should be compressed 4" to 6". This means that the maximum recommended seal is 10" for a 4" bumper and the minimum recommended bumper is 6" for a 12" seal. Anything over 6" of compression does not create a better seal; rather, it just makes the seal wear out faster.

It seems that the more specialized the building project is, the more likely the loading dock will be treated as unimportant and will be set up incorrectly. For example, some of the worst loading docks that we have seen are on hospitals.

Many times, the dock seal and shelter cover fabric specifications are based on some of the more expensive rubber based products that have been very heavily promoted by the dock seal industry leaders. Although these fabrics have a good reputation, from a durability standpoint the important factor is not whether the coating is rubber or vinyl, but rather is the base fabric? The base fabric of a material is the interwoven nylon or polyester strands sandwiched between the two layers of rubber or vinyl. The thickness and quality of the strands determines the tear strength of the material. In some cases, there are very commonly specified light duty base fabrics used in conjunction with expensive rubber coatings. The end result is a product with low durability and a high cost. Nearly every manufacturer of seals and shelters has available what is generically known as "high tear vinyl". Because durability and longevity is the goal, these fabrics provide the most cost effective product.

If you need help deciding which product would best fit your situation, please feel free to give us a call at 1-800-741-1258.



Loading Dock Supply LLC

PO Box 15 Ashley, Ohio 43003

Phone 1-800-741-1258

Fax 1-866-709-2802

LoadingDockSupply.com

