

Description: GM Passlock 1, 2, VATS and ION Self Learning (NO KEY REQUIRED)

Functions: Auto learning unit designed to bypass all GM vehicles equipped with Passlock 1, 2, VATS & ION Style

Downloadable Firmware for Platform #06: PKG5, PKG7, PKG9, PLXR

WARNING: Before beginning your install go to www.XPRESSKIT.com and be sure to print the LATEST corresponding installation manual for the firmware that is flashed to the platform you are using.

INSTALLATION "A": COBALT, PURSUIT

Section A
SEE WIRE CONNECTION GUIDE FOR DETAILED INFORMATION REGARDING WIRE FUNCTIONALITY

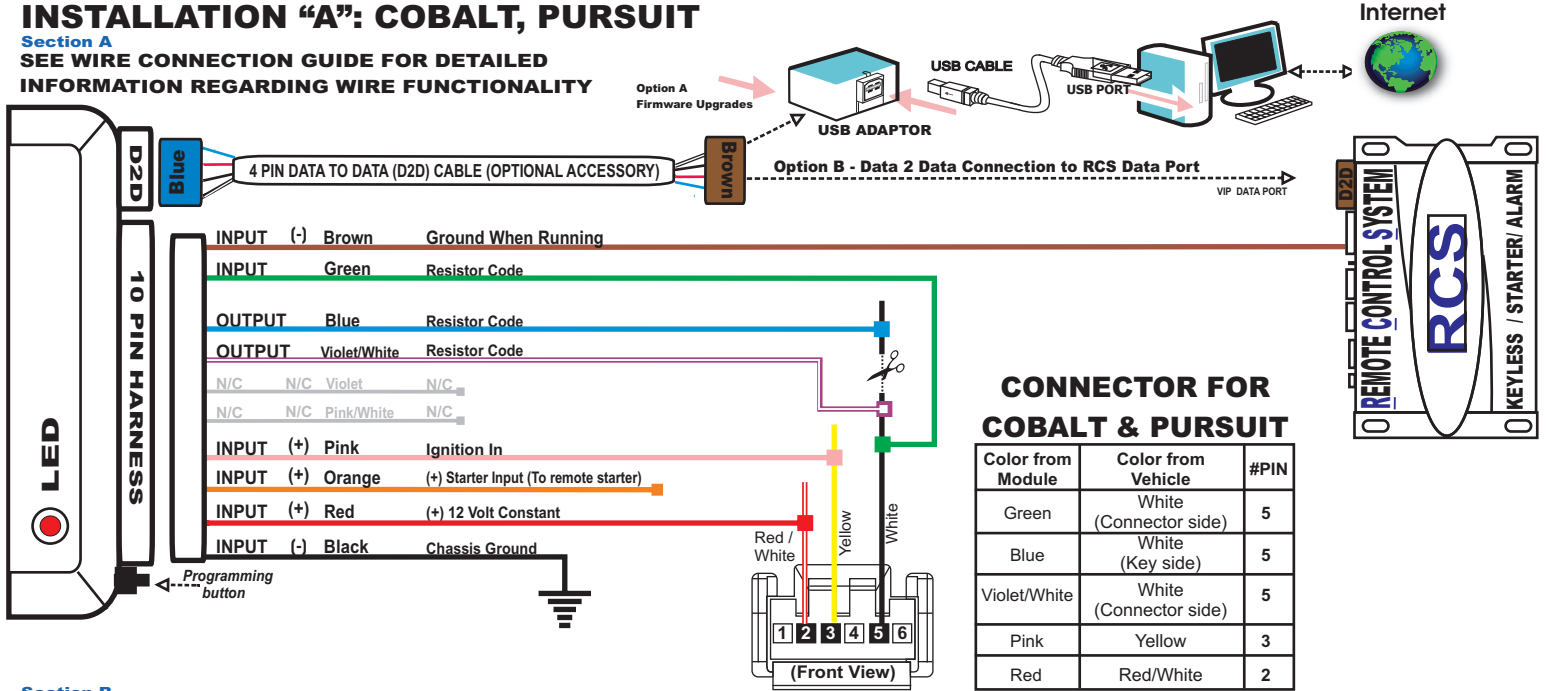

Section B
WIRE GUIDE: CONNECTIONS

10 PIN HARNESS → D2D = Optional use of 4 Pin Data to Data (D2D) cable will replace the analogue wire (w2w) connection

PIN#	WIRE COLOR	D2D w2w	I/O STATUS	(-) / (+)	Connect Location	SPECIFIC WIRE CONNECTION LOCATION	ACTIVATION and/or FUNCTIONALITY
1	Brown	D2D w2w	Input	(-)	RCS	Ground When Running Output of Remote Starter	Bypass OEM Passlock
2	Green	w2w	Input		Vehicle	Connect to White Resistance wire in Ignition Switch Connector (Cylinder Side) at PIN 5	Resistance Value in order to Bypass OEM Passlock
3	Blue	w2w	Output		Vehicle	Connect to White Resistance wire in Ignition Switch Connector (BCM Side) at PIN 5	Resistance Value in order to Bypass OEM Passlock
4	Violet/White	w2w	Input		Vehicle	Connect to White Resistance wire in Ignition Switch Connector (Cylinder Side) at PIN 5	Resistance Value in order to Bypass OEM Passlock
5	Violet	N/C	N/C	N/C	N/C	N/C	N/C
6	Pink/White	N/C	N/C	N/C	N/C	N/C	N/C
7	Pink	w2w	Input	(+)	Vehicle	Connect to Yellow wire at Ignition Switch Connector at PIN 3	Ignition Power Source
8	Orange	w2w	Input	(+)	RCS	Connect to start output wire of remote control system	Starts Vehicle
9	Red	D2D w2w	Input	(+)	Vehicle	Connect to Red/White wire at Ignition Switch Connector at PIN 2 (Constant (+) 12 Volt Source)	Power Source
10	Black	D2D w2w	Input	(-)	Vehicle	Chassis Ground	Ground Source

Legend RCS = Remote Control System N/C = No Connection N/A = Not Applicable W2W= analogue wire to wire D2D= data 2 data

DATA TO DATA PORT (D2D): Blue connector of D2D Cable plugs into the upgradeable vehicle interface module.
 OPTION A: - D2D Port used to connect to USB Bootloader adaptor & computer to download & flash vehicle interface firmware.
 OPTION B: - D2D Port used to connect to the data port of a remote control system equipped with ClearCode Vehicle Interface Protocol.
 Remote control systems designed with ClearCode VIP can securely communicate via the D2D cable to transmit & receive data commands which initiate specific vehicle function such as doorlocks & immobilizer override and /or request information from the vehicle such as status of entry points (doors) or ambient temperature, diesel glow plug etc. ClearCode VIP represents the doorway to vehicle integration.

Section C
INSTALLATION TYPE "A" PROGRAMMING SELECTION

STEP 1- PASSLOCK TYPE SELECTION

Once all Passlock wires have been connected, you must SELECT the proper **PASSLOCK TYPE** before proceeding to STEP 2 -PROGRAM RESISTOR CODE. Select one of the 3 available PASSLOCK types:

- To enter PASSLOCK TYPE SELECTION: Plug 10 PIN connector in the module, then LED will flash to indicate TYPE.
- Press programming button 1, 2 or 3 times to select the Passlock Type. LED will flash an equal number of times to confirm selection.
 PASSLOCK 1 / VATS = Press Button (1X) one time
 PASSLOCK 2 = Press Button (2X) two times
 COLORADO/ION = Press Button (3X) three times

- To Save & Exit Passlock Selection Type: Press and hold the programming button until LED flashes one time rapidly.

STEP 2- PROGRAM RESISTOR CODE

Connect Brown wire to remote starter **ONLY AFTER** RESISTOR CODE programming is complete.

- Turn Key to ignition position.
- Press & hold Programming Button while key is in the ignition position. LED will come on for 1 SEC, then turn off. The relay in the module will "click" once.
- Start the engine and hold the key at start position, press and hold the programming button one more time, LED will come ON 1 sec, then turn OFF. The relay in the module will click once again.
- Passlock Resistor Code is now programmed, connect brown wire to ground output from remote starter and test function by remote starting the engine. (For manual transmission vehicles, put shifter in NEUTRAL position and DON'T PRESS CLUTCH when doing STEP B, C & D)

Reset

- Unplug 10 pin harness. Press and hold the programming button while re-plugging 10 pin harness to module.
- Release the programming button, within 2-3 seconds the LED confirms reset status by rapidly flashing.
- The module is now reset and has returned to default setting.

Description: GM Passlock 1, 2, VATS and ION Self Learning (NO KEY REQUIRED)

Functions: Auto learning unit designed to bypass all GM vehicles equipped with Passlock 1, 2, VATS & ION Style

Downloadable Firmware for Platform #06: PKG5, PKG7, PKG9, PLXR

WARNING: Before beginning your install go to www.XPRESSKIT.com and be sure to print the LATEST corresponding installation manual for the firmware that is flashed to the platform you are using.

INSTALLATION "B": ION

Section A
SEE WIRE CONNECTION GUIDE FOR DETAILED INFORMATION REGARDING WIRE FUNCTIONALITY

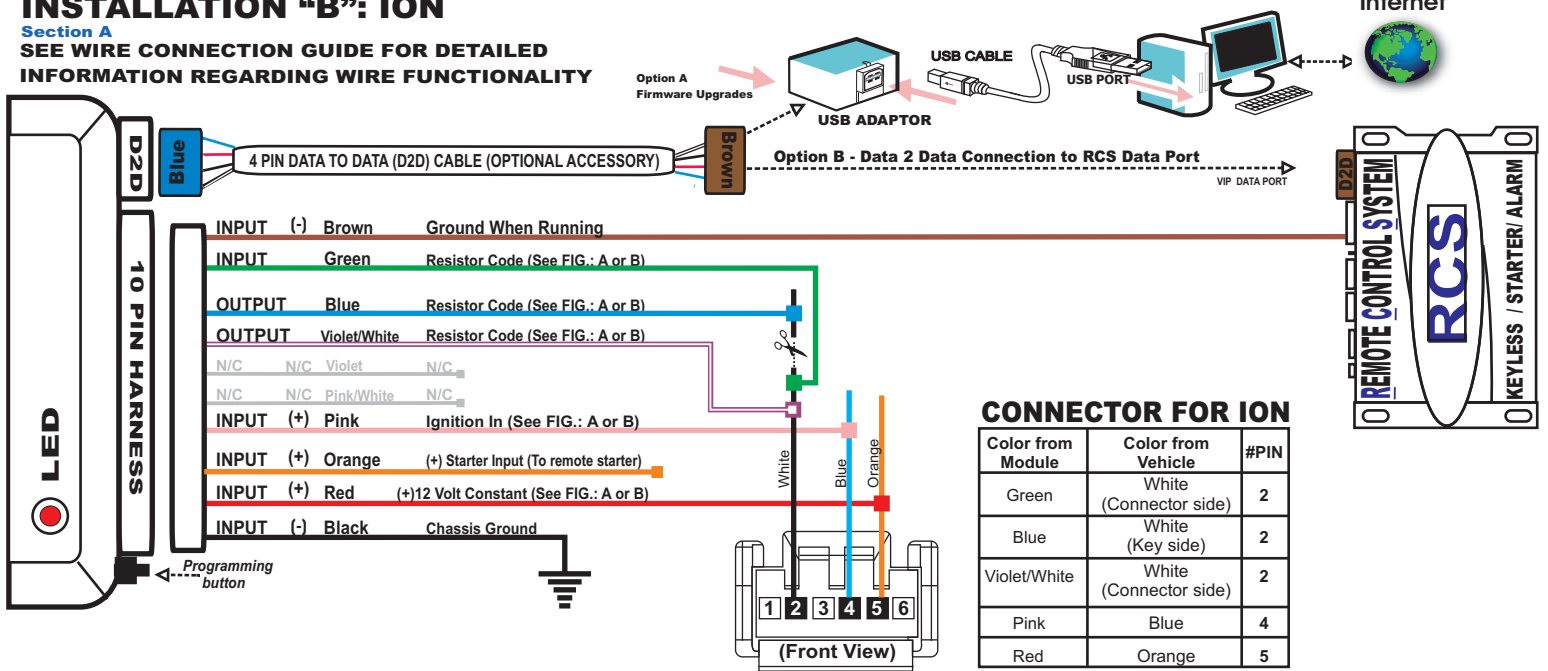

Section B
WIRE GUIDE: CONNECTIONS

10 PIN HARNESS → D2D = Optional use of 4 Pin Data to Data (D2D) cable will replace the analogue wire (w2w) connection

PIN#	WIRE COLOR	D2D w2w	I/O STATUS	(-)/(+)	Connect Location	SPECIFIC WIRE CONNECTION LOCATION	ACTIVATION and/or FUNCTIONALITY
1	Brown	D2D w2w	Input	(-)	RCS	Ground When Running Output of Remote Starter	Bypass OEM Passlock
2	Green	w2w	Input		Vehicle	Connect to White Resistance wire in Ignition Switch Connector (Cylinder Side) at PIN 2	Resistance Value in order to Bypass OEM Passlock
3	Blue	w2w	Output		Vehicle	Connect to White Resistance wire in Ignition Switch Connector (BCM Side) at PIN 2	Resistance Value in order to Bypass OEM Passlock
4	Violet/White	w2w	Input		Vehicle	Connect to White Resistance wire in Ignition Switch Connector (Cylinder Side) at PIN 2	Resistance Value in order to Bypass OEM Passlock
5	Violet	N/C	N/C	N/C	N/C	N/C	N/C
6	Pink/White	N/C	N/C	N/C	N/C	N/C	N/C
7	Pink	w2w	Input	(+)	Vehicle	Connect to Blue wire in Ignition Switch Connector at PIN 4	Ignition Power Source
8	Orange	w2w	Input	(+)	RCS	Connect to start output wire of remote control system	Starts Vehicle
9	Red	D2D w2w	Input	(+)	Vehicle	Connect to Orange wire in Ignition Switch Connector at PIN 5 (Constant (+) 12 Volt Source)	Power Source
10	Black	D2D w2w	Input	(-)	Vehicle	Chassis Ground	Ground Source

Legend RCS = Remote Control System N/C = No Connection N/A = Not Applicable W2W= analogue wire to wire D2D= data 2 data

DATA to DATA PORT (D2D): Blue connector of D2D Cable plugs into the upgradeable vehicle interface module.

OPTION A: - D2D Port used to connect to USB Bootloader adaptor & computer to download & flash vehicle interface firmware.

OPTION B: - D2D Port used to connect to the data port of a remote control system equipped with ClearCode Vehicle Interface Protocol.

Remote control systems designed with ClearCode VIP can securely communicate via the D2D cable to transmit & receive data commands which initiate specific vehicle function such as doorlocks & immobilizer override and /or request information from the vehicle such as status of entry points (doors) or ambient temperature, diesel glow plug etc. ClearCode VIP represents the doorway to vehicle integration.

Section C
INSTALLATION TYPE "B" PROGRAMMING SELECTION

STEP 1- PASSLOCK TYPE SELECTION

Once all Passlock wires have been connected, you must SELECT the proper **PASSLOCK TYPE** before proceeding to STEP 2 -PROGRAM RESISTOR CODE. Select one of the 3 available PASSLOCK types:

- To enter PASSLOCK TYPE SELECTION: Plug 10 PIN connector in the module, then LED will flash to indicate TYPE.
- Press programming button 1, 2 or 3 times to select the Passlock Type. LED will flash an equal number of times to confirm selection.
PASSLOCK 1 / VATS = Press Button (1X) one time
PASSLOCK 2 = Press Button (2X) two times
COLORADO/ION = Press Button (3X) three times

- To Save & Exit Passlock Selection Type: Press and hold the programming button until LED flashes one time rapidly.

STEP 2- PROGRAM RESISTOR CODE

Connect Brown wire to remote starter **ONLY AFTER** RESISTOR CODE programming is complete.

- Turn Key to ignition position.
- Press & hold Programming Button while key is in the ignition position. LED will come on for 1 SEC, then turn off. The relay in the module will "click" once.
- Start the engine and hold the key at start position, press and hold the programming button one more time, LED will come ON 1 sec, then turn OFF. The relay in the module will click once again.
- Passlock Resistor Code is now programmed, connect brown wire to ground output from remote starter and test function by remote starting the engine. (For manual transmission vehicles, put shifter in **NEUTRAL** position and **DON'T PRESS CLUTCH** when doing STEP B, C & D)

Reset

- Unplug 10 pin harness. Press and hold the programming button while re-plugging 10 pin harness to module.
- Release the programming button, within 2-3 seconds the LED confirms reset status by rapidly flashing.
- The module is now reset and has returned to default setting.

Description: GM Passlock 1, 2, VATS and ION Self Learning (NO KEY REQUIRED)

Functions: Auto learning unit designed to bypass all GM vehicles equipped with Passlock 1, 2, VATS & ION Style

INSTALLATION "C": COLORADO, CANYON & H3

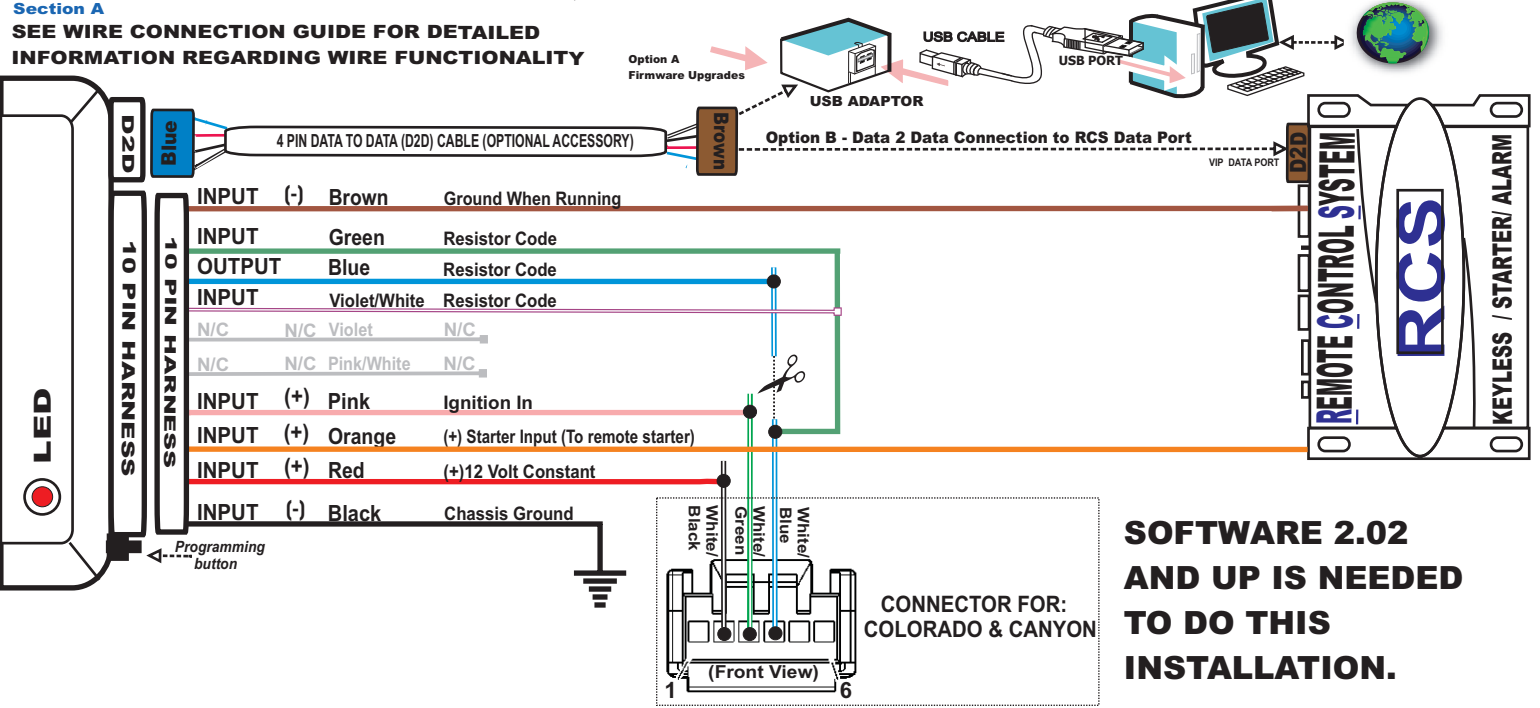

Section B
WIRE GUIDE: CONNECTIONS

10 PIN HARNESS → D2D = Optional use of 4 Pin Data to Data (D2D) cable will replace the analogue wire (w2w) connection

PIN#	WIRE COLOR	D2D w2w	I/O STATUS	(-) /(+)	Connect Location	SPECIFIC WIRE CONNECTION LOCATION	ACTIVATION and/or FUNCTIONALITY
1	Brown	D2D w2w	Input	(-)	RCS	Ground When Running Output of Remote Starter	Bypass OEM Passlock
2	Green	w2w	Input		Vehicle	Connect to White/Blue Resistance wire PIN 4 of Ignition Switch Connector (Cylinder Side)	Resistance Value in order to Bypass OEM Passlock
3	Blue	w2w	Output		Vehicle	Connect to White/Blue Resistance wire PIN 4 of Ignition Switch Connector (BCM Side)	Resistance Value in order to Bypass OEM Passlock
4	Violet/White	w2w	Input		Vehicle	Connect to White/Blue Resistance wire PIN 4 of Ignition Switch Connector (Cylinder Side)	Resistance Value in order to Bypass OEM Passlock
5	Violet	N/C	N/C	N/C	N/C	N/C	N/C
6	Pink/White	N/C	N/C	N/C	N/C	N/C	N/C
7	Pink	w2w	Input	(+)	Vehicle	Connect to White/Green wire PIN 3 of Ignition Switch Connector	Ignition Power Source
8	Orange	w2w	Input	(+)	RCS	Connect to start output wire of remote control system	Starts Vehicle
9	Red	D2D w2w	Input	(+)	Vehicle	Connect to White/Black wire PIN 2 of Ignition Switch Connector (Constant (+) 12 Volt Source)	Power Source
10	Black	D2D w2w	Input	(-)	Vehicle	Chassis Ground	Ground Source

Legend RCS = Remote Control System N/C = No Connection N/A = Not Applicable W2W= analogue wire to wire D2D= data 2 data

DATA to DATA PORT (D2D): Blue connector of D2D Cable plugs into the upgradeable vehicle interface module.
OPTION A: - D2D Port used to connect to USB Bootloader adaptor & computer to download & flash vehicle interface firmware.
OPTION B: - D2D Port used to connect to the data port of a remote control system equipped with ClearCode Vehicle Interface Protocol.
 Remote control systems designed with ClearCode VIP can securely communicate via the D2D cable to transmit & receive data commands which initiate specific vehicle function such as doorlocks & immobilizer override and/or request information from the vehicle such as status of entry points (doors) or ambient temperature, diesel glow plug etc. ClearCode VIP represents the doorway to vehicle integration.

Section C
INSTALLATION TYPE "C" PROGRAMMING SELECTION

STEP 1- PASSLOCK TYPE SELECTION
 Once all Passlock wires have been connected, you must SELECT the proper PASSLOCK TYPE before proceeding to STEP 2 -PROGRAM RESISTOR CODE. Select one of the 3 available PASSLOCK types:
 1.To enter PASSLOCK TYPE SELECTION: Plug 10 PIN connector in the module, then LED will flash to indicate TYPE.
 2.Press programming button 1, 2 or 3 times to select the Passlock Type. LED will flash an equal number of times to confirm selection.
 PASSLOCK 1 / VATS = Press Button (1X) one time
 PASSLOCK 2 = Press Button (2X) two times
 COLORADO/ION = Press Button (3X) three times
 * System is preset for Colorado/Canyon/ION Type
 3.To Save & Exit Passlock Selection Type: Press and hold the programming button until LED flashes one time rapidly.

STEP 2- PROGRAM RESISTOR CODE
 Connect Brown wire to remote starter **ONLY AFTER** RESISTOR CODE programming is complete.
A) Turn Key to ignition position.
B) Press & hold Programming Button while key is in the ignition position. LED will come on for 1 SEC, then turn off. The relay in the module will "click" once.
C) Start the engine and hold the key at start position, press and hold the programming button one more time, LED will come ON 1 sec, then turn OFF. The relay in the module will click once again.
D) Passlock Resistor Code is now programmed, connect brown wire to ground output from remote starter and test function by remote starting the engine. (For manual transmission vehicles, put shifter in NEUTRAL position and DON'T PRESS CLUTCH when doing STEP B, C & D)

Reset
 1.Unplug 10 pin harness. Press and hold the programming button while re-plugging 10 pin harness to module.
 2.Release the programming button, within 2 -3 seconds the LED confirms reset status by rapidly flashing.
 3.The module is now reset and has returned to default setting.

Description: GM Passlock 1, 2, VATS and ION Self Learning (NO KEY REQUIRED)

Functions: Auto learning unit designed to bypass all GM vehicles equipped with Passlock 1, 2, VATS & ION Style

INSTALLATION "D": PASSLOCK 1, 2 & VATS CONNECTION

Section A
SEE WIRE CONNECTION GUIDE FOR DETAILED INFORMATION REGARDING WIRE FUNCTIONALITY

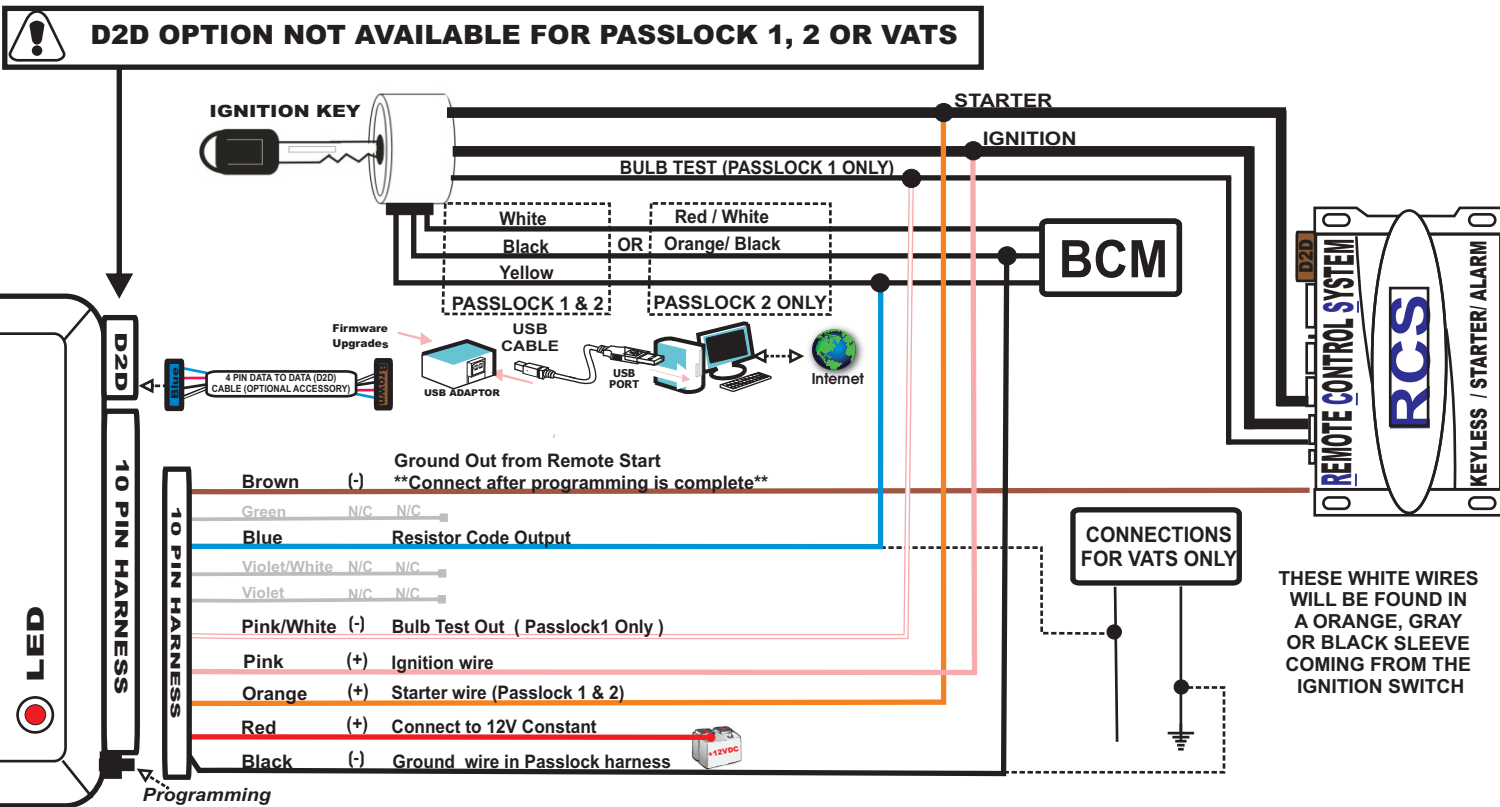

Section B WIRE GUIDE: CONNECTIONS

10 PIN HARNESS → D2D = Optional use of 4 Pin Data to Data (D2D) cable will replace the analogue wire (w2w) connection

PIN#	WIRE COLOR	VEHICLE TYPE	D2D w2w	I/O STATUS	(-) / (+)	Connect Location	SPECIFIC WIRE CONNECTION LOCATION	ACTIVATION and/or FUNCTIONALITY
1	Brown		w2w	Input	(-)	RCS	Ground When Running Output of Remote Starter - IMPORTANT: CONNECT ONLY AFTER PROGRAMMING IS COMPLETE	Bypass OEM Passlock
2	Green	N/C	N/C	N/C	N/C	N/C	N/C	N/C
3	Blue	Passlock 1 & 2 VATS	w2w w2w	Output		Vehicle Vehicle	Connect to Yellow Resistance wire coming from Ignition Cylinder (See Install Type "C") Connect to White Resistance wire	Resistance Value in order to Bypass OEM Passlock
4	Violet/White	N/C	N/C	N/C	N/C	N/C	N/C	N/C
5	Violet	N/C	N/C	N/C	N/C	N/C	N/C	N/C
6	Pink/White	Passlock 1	w2w	Input	(-)	Vehicle	Connect to Black 24ga Bulb Test wire found in top plug of Ignition cylinder (See Install Type "C")	
7	Pink	Passlock 1, 2 & VATS	w2w	Output	(+)	Vehicle	Connect to Ignition wire coming from Ignition cylinder	Ignition Power Source
8	Orange	Passlock 1 & 2	w2w	Input	(+)	Vehicle	Connect in parallel with vehicle and remote control system start output wire.	Starts Vehicle
9	Red	Passlock 1, 2 & VATS	w2w	Input	(+)	Vehicle	Constant (+) 12 Volt Source	Power Source
10	Black	Passlock 1	w2w	Input	(-)	Vehicle	Connect to Black wire coming from Ignition Cylinder (Chassis Ground)	Ground Source
		Passlock 2	w2w	Input	(-)	Vehicle	Connect to Black or Orange/Black wire coming from Ignition Cylinder	Ground Source
		VATS	w2w	Input	(-)	Vehicle	Connect to White wire located in VATS harness coming from ignition cylinder. This wire will show true ground without key in cylinder.	Ground Source

Legend RCS = Remote Control System N/C = No Connection N/A = Not Applicable W2W= analogue wire to wire D2D= data 2 data

Section C INSTALLATION TYPE "D": PROGRAMMING SELECTION

STEP 1- PASSLOCK TYPE SELECTION

Once all Passlock wires have been connected, you must SELECT the proper PASSLOCK TYPE before proceeding to STEP 2 -PROGRAM RESISTOR CODE. Select one of the 3 available PASSLOCK types:

1. To enter PASSLOCK TYPE SELECTION: Plug 10 pin connector in the module, then LED will flash to indicate TYPE.
2. Press programming button 1, 2 or 3 times to select the Passlock Type. LED will flash an equal number of times to confirm selection.
PASSLOCK 1 / VATS = Press Button (1X) one time
PASSLOCK 2 = Press Button (2X) two times
COLORADO/ION = Press Button (3X) three times

3. To Exit Passlock Selection Type: Press and hold the programming button until LED flashes one time rapidly.

STEP 2- PROGRAM RESISTOR CODE

Connect Brown wire to remote starter **ONLY AFTER** RESISTOR CODE programming is complete.

- A) Start vehicle by key.
- B) Press & hold Programming Button. LED will come on for 1 SEC, then turn off. Turn key to OFF position.
- C) Passlock Resistor Code is now programmed, connect brown wire to ground output from remote starter and test function by remote starting the engine.
(For manual transmission vehicles, put shifter in NEUTRAL position and DON'T PRESS CLUTCH when doing STEP B)

Reset

1. Unplug 10 pin harness. Press and hold the programming button while re-plugging 10 pin harness to module.
2. Release the programming button, within 2 -3 seconds the LED confirms reset status by rapidly flashing.
3. The module is now reset and has returned to default setting.

Description: GM Passlock 1, 2, VATS and ION Self Learning (NO KEY REQUIRED)

Functions: Auto learning unit designed to bypass all GM vehicles equipped with Passlock 1, 2, VATS & ION Style

INSTALLATION “A”, “B” & “C” NOTES:

*Saturn ION, GMC Canyon & Chevy Colorado etc do not have starter wires.

INSTALLATION “D” NOTES:

*The wiring of some older model Passlock 1 may also have the following color sequence: Black/White, Black (GND), Black (DATA)

** The Equinox is a PASSLOCK 2 type even though it does not have a starter wire.

TECH NOTE: * For some vehicles, (Equinox) may not be required to have transmission in Drive (D) position

ADDITIONAL INFORMATION

SUBJECT: CAVALIER,SUNFIRE 1999 OR OLDER (PASSLOCK SUPPLIED WITH BULB TEST)

Our technical department has noticed that on certain vehicles, such as Cavalier and Sunfire 1999 or older, a voltage residue coming from the starter, after vehicle is started, is present as a pulse during a few seconds . This problem only occurs on some vehicles. So, with test light, after key is back to ignition position, after being started, starter wire is to be tested . The cut must be instantly. If not the case, install 12 amp diode as mentioned in diagram below. This is to rectify situation.

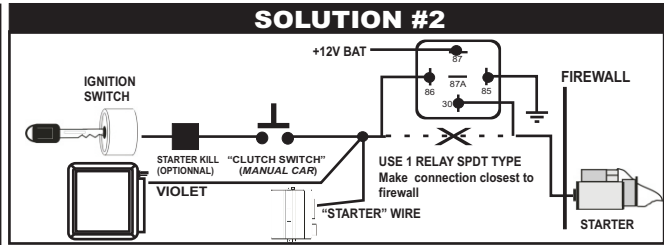
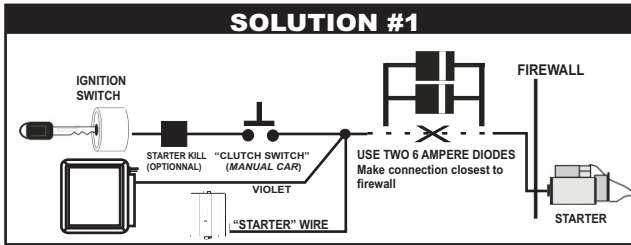

This Interface kit / Data Bus Interface part has been tested on the listed vehicles. Other vehicles will be added to the select vehicle list upon completion of compatibility testing. Visit website for latest vehicle application guide. **DISCLAIMER:** Under no circumstances shall the manufacturer or the distributors of the bypass kit / data bus interface part(s) be held liable for any consequential damages sustained in connection with the part(s) installation. The manufacturer and it's distributors will not, nor will they authorize any representative or any other individual to assume obligation or liability in relation to the interface kit / data bus interface part(s) other than its replacement. N.B.:Under no circumstances shall the manufacturer and distributors of this product be liable for consequential damages sustained in connection with this product and neither assumes nor authorizes any representative or other person to assume for it any obligation or liability other than the replacement of this product only.