

# MECHAN CONTROLS

## 'F' SERIES

### SAFETY SWITCH INSTALLATION GUIDE

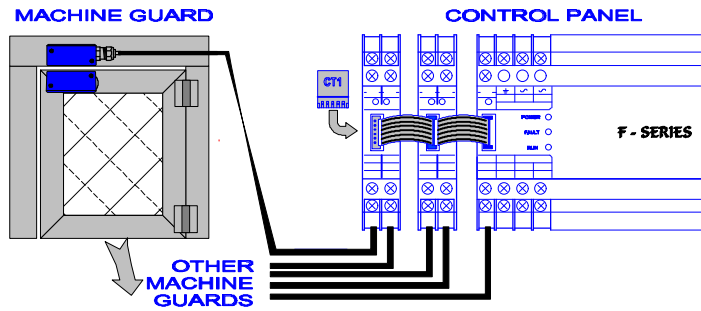

This information is designed to help suitably qualified personnel install and operate Mechan Safety Switch equipment. Before using this product, read this guide thoroughly along with any relevant European and/or National standards e.g. Machinery Directive 89/392/EEC and it's amendments, Provision and Use of Work Equipment Regulations. Further information can be obtained from Mechan Controls Limited

\*\*\*\*\* KEEP THIS GUIDE FOR FUTURE REFERENCE \*\*\*\*\*

#### CONTENTS

- |                          |   |
|--------------------------|---|
| 1 Description            | 4 Connections                               |
| 2 Product Identification | 5 Technical Specification - Control Modules |
| 3 System Assembly        | 6 Technical Specification - Safety Switches |

### 1) Description

The Mechan 'F' Series Safety Switch System is a purely electronic system for monitoring machine guards. Comprising of a Control Unit and Safety Switches, the 'F' Series uses both Dynamic Signal Processing and Dual Channel/Cross Monitoring techniques to provide a Fail-Safe system which can be used in either single or dual channel control circuits.

**The SENSORS:** Are solid state electronic devices with no contacts or moving parts. They are resin encapsulated into an ABS case, to provide a fully sealed, IP67, sensor which can withstand the most arduous of conditions. Water, dust, oil, machine vibration and even steam cleaning have little or no effect on their performance and they have a life span measured in years not months.

**The CONTROL MODULES:** All systems start with the FM1. This contains the power supply regulation, dual PGC relay outputs, the external re-set/proving circuit and system indication along with the input for one safety switch sensor and it's volt free indicator output. The FM1 and a safety switch sensor is all that is required for a system that is monitoring one guard. To build systems monitoring more than one guard, simply connect the required number of one or two channel extender modules, FX1 or FX2, to the FM1. The extenders provide connections for the safety switch sensor(s), and a volt free indicator contact output for each sensor.

### 2a) Product Identification CONTROL MODULES & EXTENDERS

#### No. Description

- 1\* Power supply input.  
(options 24, 110 or 230Vac or 24Vdc)  
**Terminals : see label (bottom row)**
- 2 Safety Switch Sensor Input.  
**Terminals : BROWN & DRAIN (bottom row)  
BLUE (top row)**
- 3 Indicator Output, N/O volt free contact.
- 4 Gate Open Indicator, Red LED.
- 5 Control Bus.
- 6\* External Relay Monitor / Re-set circuit.  
**Terminals : 2 & 3 (top row)**
- 7\* Control Output No.1, N/O volt free contact.  
**Terminals : 13 & 14**
- 8\* Control Output No.2, N/O volt free contact.  
**Terminals : 23 & 24**
- 9\* Run Indicator, Green LED.
- 10\* Fault Indicator, Red LED.
- 11\* Power On Indicator, Red LED.
- 12 Serial Number.  
(See side label on FX1/FX2)
- 13 Part Number.  
(See side label on FX1/FX2)
- 14\*\* Control Bus Connector Strap.

\* FM1 Controller Only, \*\* FX1 & FX2 Extender Only

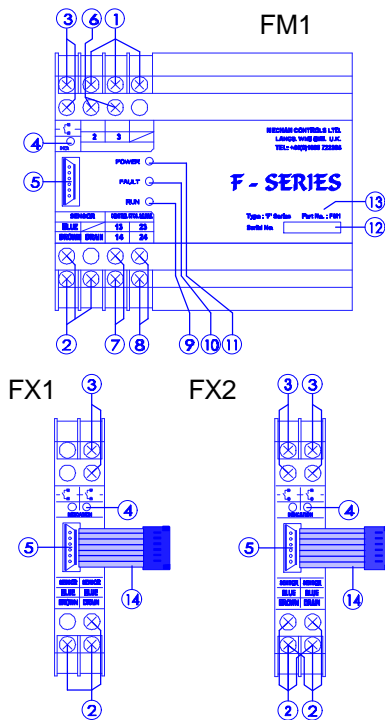

### 2b) Product Identification SAFETY SWITCH SENSORS (all types)

#### No. Description

- 1 Safety switch sensor oscillator.  
(Moving part)
- 2 Safety sensor receiver.  
(Fixed part)
- 3 Fixing holes.
- 4 Cable protection / conduit gland.
- 5 Cable encapsulated into the sensor.

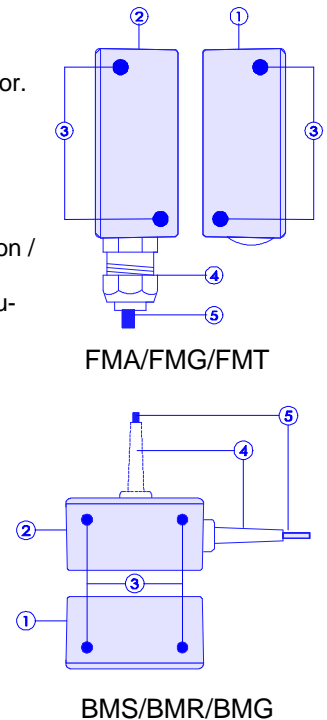

# Mechan Controls Limited

## Electronic Safety Switches

MECHAN CONTROLS LIMITED, 14/16 SEDDON PLACE, STANLEY INDUSTRIAL ESTATE, SKELMERSDALE, LANCASHIRE, WN8 8EB  
Tel : + 44 (0)1695 722264 Fax : + 44 (0)1695 729664 WEB : www.mechancontrols.co.uk Email : technical@mechancontrols.co.uk

### 3) SYSTEM ASSEMBLY

#### 3a) CLIP ON TO DIN-RAIL

The 'F' series control modules are designed to be mounted in an IP 55 (minimum) cabinet.

The modules clip on to standard 35mm symmetric (Top Hat) DIN-rail.

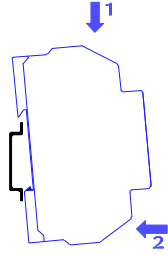

#### 3b) SINGLE GUARD SYSTEM

A system to monitor only one guard requires the FM1 control module mounted in suitable cabinet and one pair of safety switch sensors.

The 'Control Bus' terminator CT1 must be plugged in to the FM1 as shown.

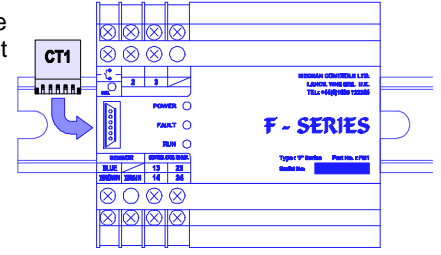

#### 3c) MULTI GUARD SYSTEMS

Most systems will require the monitoring of more than one guard.

Assemble the required number of modules on a DIN-rail starting, with the FM1 and clipping the extender modules, FX1 or FX2, to the left of the FM1.

The 'Control Bus' straps connect to the adjacent, right hand module as shown.

The maximum number of channels for a DC supply system is 30, AC systems can also have up to 29 channels but require a Power Boost unit after each additional ten channels (see PB10 guide)

The 'Control Bus' terminator CT1 must be connected to the last module.

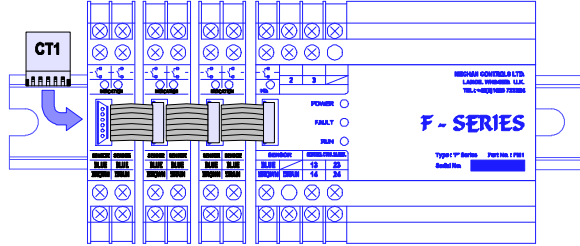

#### 3d) REMOVAL FROM DIN-RAIL

To remove the modules gently lever out the DIN clip with a small screwdriver as shown (1).

Tilt the unit in the direction (2) and slip off the DIN-rail (3).

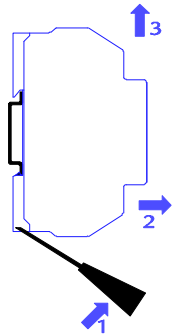

#### 3e) MOUNTING SAFETY SWITCH SENSORS

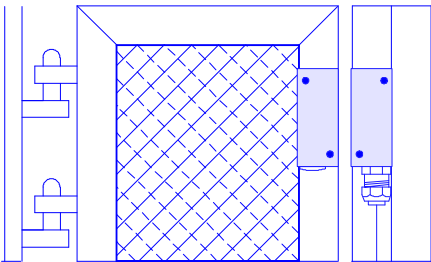

Mechan safety switch sensors have 2 pre-drilled fixing holes. (see back page for dimension / position details)

**! DO NOT enlarge the fixing holes**

Mount the Safety Switch Sensors as shown (left), ensuring that the targets on the printed faces of the sensors are facing each other and aligned. The sensors should be mounted with a gap of approximately 2 mm. between the printed faces when the guard is closed. This gives a good level of lateral tolerance to allow for 'gate sag' and freedom from nuisance tripping due to machine / guard vibration.

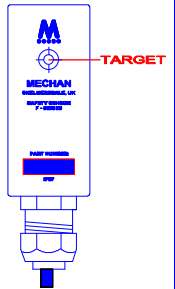

#### CABLE CONNECTION / EXTENSION

The Mechan fixed sensor has 5, 10 or 15 metres of cable potted into it when supplied. This ensures a completely water-tight seal to the electronics within the sensor.

Run the cable back to the control unit through cable protection (if required) and terminate into the appropriate input channel, following the colour coding of the wires to the labels on the input terminals.

NOTE:

- 1) The FX2 requires the commoning of the supply and drain wires (Brown / Drain) from 2 pairs of sensors, as shown opposite.
- 2) The sensor cable may be extended if required using a similar type cable (Belden ref. 8761 or equivalent)
- 3) Cable runs of up to 100 metres will not significantly affect performance.
- 4) Multi-way versions of **individually screened, twisted pair** cable may be used to run a number of sensors back to the control unit.
- 5) Cable joints should be moisture proof and NOT EARTHED. The only earth connection must be via the drain terminal.

FX1 SENSOR CONNECTION

FX2 SENSOR CONNECTION

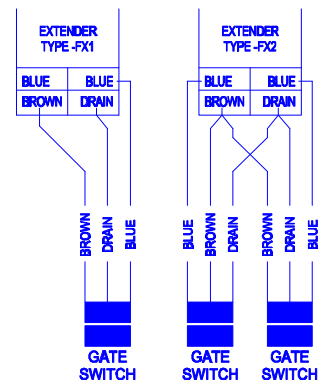

**TREAT AS INSTRUMENT CABLES AND KEEP SEPARATE FROM POWER CABLES (150mm separation is normally adequate)**

#### GATE CLOSING

The moving sensor may approach the fixed sensor from any direction. When the guard is closed the targets must be aligned and facing each other.

**Mechan sensors are suitable for use on hinged, sliding or removable guards.**

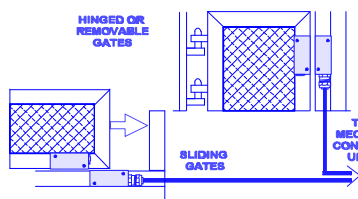

#### TEMPERATURE

Mechan safety switches can operate in temperatures from -20° to +50°C. Sensors may be mounted to a hot surface, using nylon spacers and screws as shown.

Maximum cable temperature 60°C

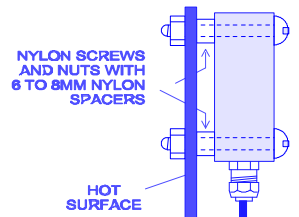

4)

## CONNECTIONS

### 4a) SINGLE CHANNEL CONTROL CIRCUITS

#### POWER SUPPLY

- 1 The FM1 base module is available to suit 24 / 110 / 230Vac (+/- 10% 6VA) and 24Vdc. Specify the voltage when ordering.
- 2 For 24Vdc systems the supply must be regulated +/- 5% and the negative must be at earth potential.
- 3 The FM1 must be connected to a 'Clean' local earth.

#### RE-SET / PROVING

- 1 In single control channel systems, a momentary, normally open re-set button should be connected across terminals 2 and 3.
- 2 Use screened cable for the Re-set/Proving circuit.

#### INDICATION

- 1 The indicator contacts are normally open. When a guard is opened the indicator contact for that channel closes, the guard open LED will also illuminate.  
(These contacts are for indication only)

#### CONTROL CONTACTS

- 1 The FM1 has two positively guided N/O control contacts brought out to terminals, 13,14; and 23,24.
- 2 The relay contacts have a maximum 2A rating and the supply to be switched should be fused.
- 3 In single control channel systems these contacts should be linked in series.

#### SYSTEM OPERATION

- 1 When power is applied to the control module, the RED POWER LED and RED FAULT LED will illuminate.
- 2 If all the monitored machine guards are closed and the RE-SET button is pressed the RED FAULT LED will be extinguished and the GREEN RUN LED will illuminate. The control relays are then energized and the contacts on terminals 13,14 / 23,24 will be closed.
- 3 K1 can be energized using the start buttons.
- 4 K1 will be de-energized if: a) A Stop Button (or Emergency Stop Button) is pressed. b) A monitored guard is opened. or c) Power to the FM1 is lost.
- 5 When the guards have been closed and the re-set button pressed, the FM1 control relays will be energized closing the contacts on terminals 13,14 / 23,24. This will allow K1 to be operated via the Start and Stop buttons.

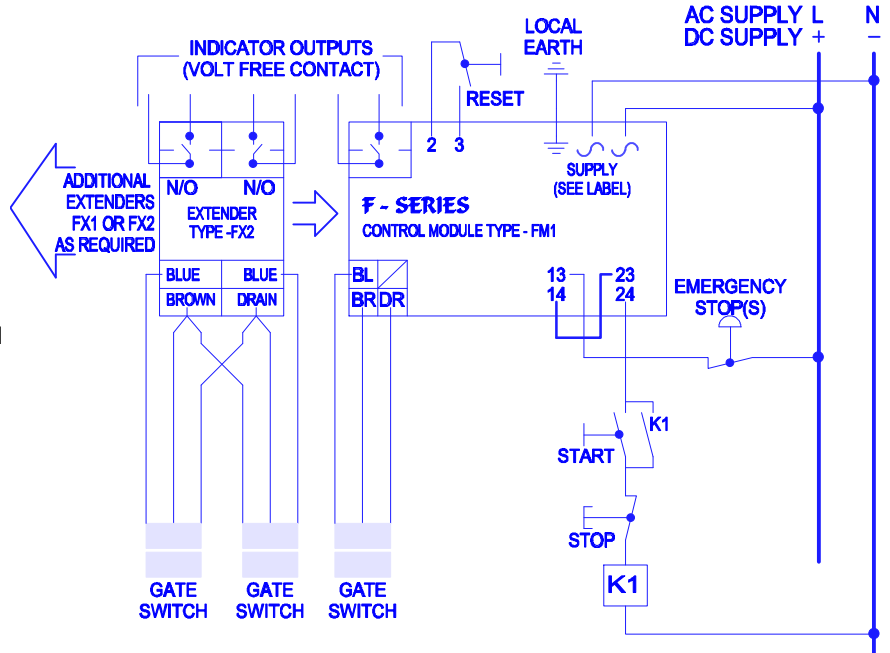

### 4b) DUAL CHANNEL CONTROL CIRCUITS

#### POWER SUPPLY

- 1 See Above

#### RE-SET / PROVING

- 1 In dual control channel systems, the re-set / proving circuit (terminals 2 & 3) are used not only as a re-set function (as above) but also to monitor the main contactors / starters K1 & K2.
- 2 Link normally closed contacts on K1 and K2 in series with the re-set button and terminals 2 & 3.
- 3 This ensures that the FM1 can only be re-set if both K1 and K2 are de-energized.
- 4 Use screened cable for the Re-set/Proving circuit.

NOTE: K1 & K2 should have positively guided contacts

#### CONTROL CONTACTS

- 1 The FM1 has two positively guided, N/O control contacts brought out to terminals, 13,14; and 23,24.
- 2 The relay contacts have a maximum 2A rating and the supply to be switched should be fused.
- 3 In dual control channel systems the control contacts, terminal 13,14 and 23,24 should be used individually to switch two separate contactors / starters.

#### SYSTEM OPERATION

- 1 System operation for a dual channel control is exactly the same as the single channel control.
- 2 An additional level of safety is achieved by duplicating the control channels. If a fault occurs in either channel ( i.e. K1 or K2 weld) the other channel will be de-energized when the stop button is pressed or a guard is opened thus maintaining the safety function.
- 3 When all gates have been closed and the FM1 requires a re-set, the proving circuit, terminals 2 & 3 will prevent a re-start as the normally closed contact on the welded relay will not be made. The RED FAULT LED will be illuminated.

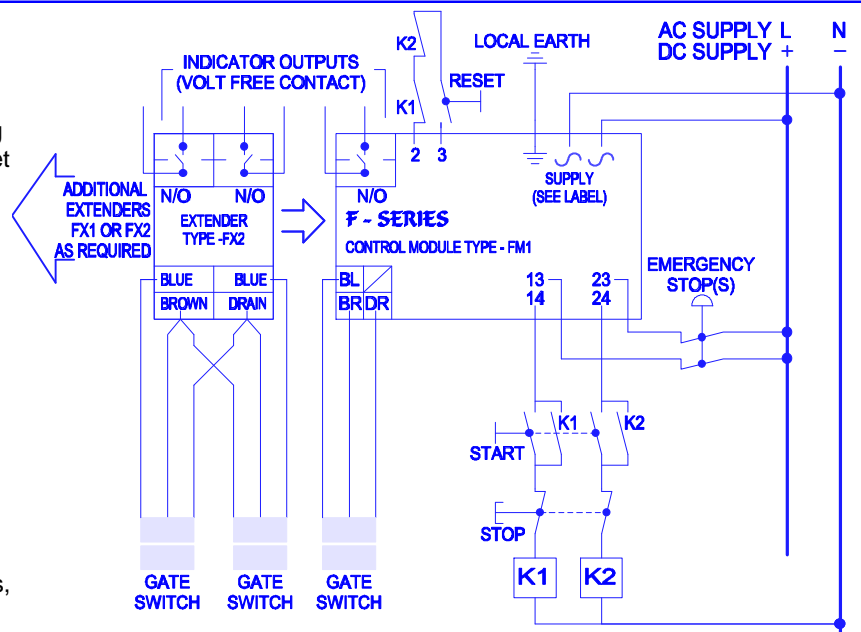

# 5) TECHNICAL SPECIFICATIONS

5a) CONTROL MODULES	
Part Number	FM1
Supply Voltages	230/110/24Vac or 24Vdc
Consumption	AC = 6VA DC = 100mA + 20mA/Channel
Max. Switching Capacity	2A/230Vac or 2A/30Vdc
Protection	IP20
Dimensions	90 x 105 x 59 MM
Fitting	35MM DIN Rail
Operating Temp.	0° to 45°C (Storage Temp. -20° to 50°C)
System Indication Channel	Power, Run & Fault LED's
Indication	1 x Red LED & 1 x N/O contact (0.5A @ 125Vac res.)

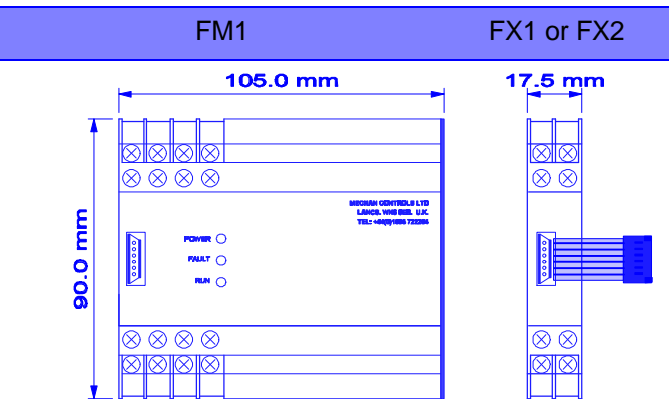

5b) EXTENDER MODULES		
Part Number	FX1	FX2
Protection	IP20	IP20
Dimensions	90 X 17.5 X 59 mm	90 X 17.5 X 59 MM
Fitting	35MM DIN Rail	35MM DIN Rail
Operating Temp.	0° to 45°C	0° to 45°C
Storage Temp.	-20° to 50°C	-20° to 50°C
Channel Indication	1 x Red LED & 1 x N/O contact. (0.5A @ 125Vac res.)	2 x Red LED & 2 x N/O contact (0.5A @ 125Vac res.)

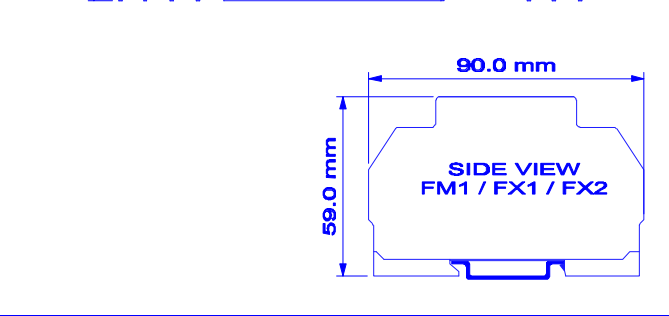

## 6a) SAFETY SENSORS - 'F' TYPE FMA / FMG / FMT

Part Number(s)	FMA / FMG / FMT (+ cable length i.e. 5m / 10m)
Construction	ABS Case; Resin filled
IP Rating	IP67
Fixing	6 mm diameter holes
Cable Type	Single Twisted pair, Foil Shield & Drain
Cable Lengths Available	5,10 & 15 metres (longer available to order)
<b>Cable Protection Adaptors</b>	
Part Number -FMA	Nickel Plated Brass, 16 mm liquid tight flexible conduit
FMG	Nylon Cord Grip, 4 to 11 mm
FMT	20 mm Brass Male Thread

(The above cable adaptors are available from stock, specials can be made to order)

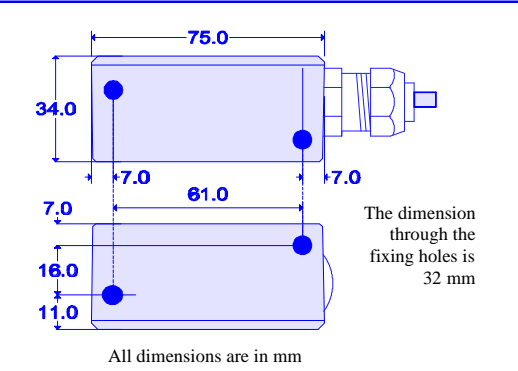

## 6b) SAFETY SENSORS - 'B' TYPE BMS / BMR / BMG

Part Number(s)	BMS / BMG / BMR (+ cable length i.e. 5m / 10m)
Construction	ABS Case; Resin filled
IP Rating	IP67
Fixing	4 mm diameter holes (nylon fixing screws supplied)
Cable Type	Single Twisted pair, Foil Shield & Drain
Cable Lengths Available	5,10 & 15 metres (longer available to order)
<b>Cable Protection Adaptors</b>	
Part Number -BMS	Tapered Rubber Grommet, side entry
BMR	Tapered Rubber Grommet, rear entry
BMG	16 mm Flexible conduit gland

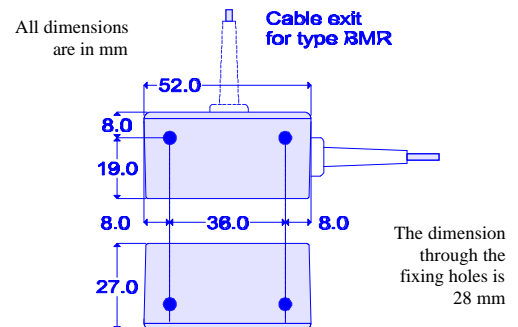

## 6c) GENERAL OPERATING SPECIFICATION FOR SENSORS

SWITCHING DISTANCE	7 to 10 mm (Must make 5 mm / Must Break 15 mm)
OPTIMUM GAP	2 mm
LATERAL TOLERANCE AT 2 mm GAP	8 mm
OPERATING TEMPERATURES	-20° to 50°C (Short term 100°C; i.e. Hot hosing down is acceptable)
MAXIMUM CABLE LENGTH	100 metres, with some slight reduction in switching distance.

**CE** The 'F' series Mechan Safety switch complies with all relevant Essential Health and Safety Requirements of the Machinery Directive (89/392/EEC & amendments 91/368/EEC, 94/44/EEC). The 'F' series has been independently tested to meet the 'Heavy Industrial' Specification of the EMC Directive for both emissions and immunity (BS EN 50081-2 & 50082-2) The CE marking relates to the EMC Directive. Copies of the Certificate of Conformity can be obtained from Mechan Controls Limited

In the interest of product development, specifications are subject to change without notice. Document No. - 327-400v4 8/9/00

It is the responsibility of the user to ensure compliance with any acts or by-laws in force.

All information regarding Mechan equipment is believed to be accurate at the time of printing. Responsibility cannot be accepted for errors or omissions.