

General features of prewired switches FA-FB-FF series

Orientable heads



In the switches with push button style actuator by removing fastening screws it is possible to rotate the actuators in 90° steps.



In the switches with revolving levers style actuator by removing fastening screws it is possible to rotate the head in 180° steps.

Adjustable levers

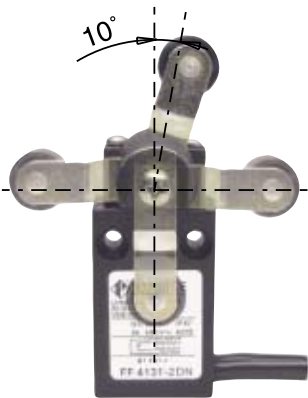

In the switches with revolving levers it is possible to adjust the lever in 10° steps for all the 360° range. The positive motion transmission is always guaranteed thanks to the particular geometrical coupling between the lever and the revolving shaft, as prescribed for safety application by the German standard BG-GS-ET-15.



Screws driving torques

For FF series.

Tighten all the fastening screws of the head **1** or **2** with a driving torque $0,4 \div 0,6$ Nm.

Tighten all the fastening screws of the lever **3** with a driving torque $0,7 \div 0,9$ Nm.



For FA and FB series.

Tighten all the fastening screws (head **1** or **2** and lever **3**) with a driving torque $0,8 \div 1,2$ Nm.

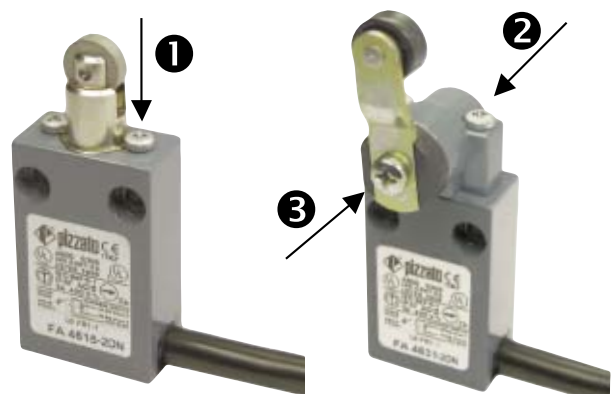

How to read travel diagrams

Slow action contact blocks 46, 48

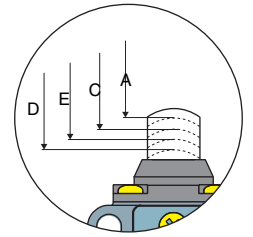
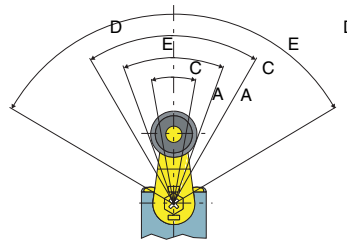
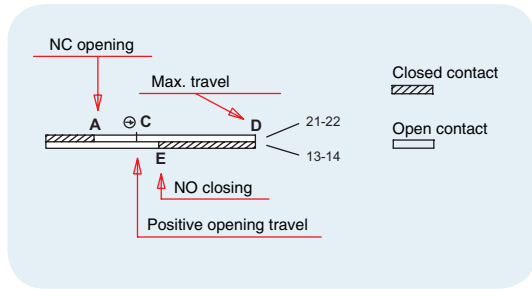

Snap action contact blocks 41, 45

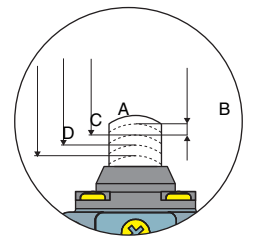
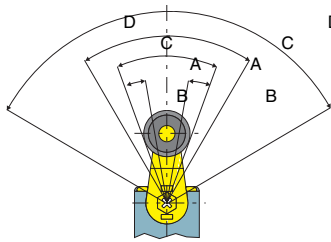
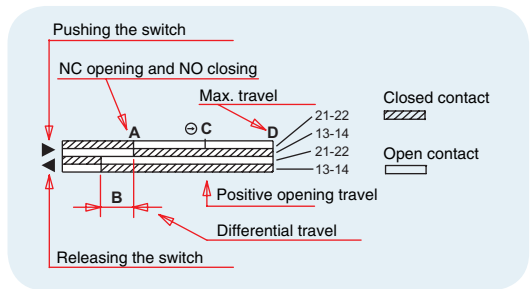

6.1

Travels diagrams table (All measures in the diagrams are in mm or degrees)

Contact block	Group 1	Group 2	Group 3	Group 4
41 1NO+1NC				
45 1NO+1NC				
46 1NO+1NC				
48 1NO+1NC				

Internal connections

FF series with cable	FA-FB series with cable	FF series with M12 connectors	FA-FB series with M12 connectors	FF series with AMP connectors
<p>Brown Black Grey Blue</p>	<p>Brown Black Grey Blue Yellow-Green</p>	<p>1 2 3 4</p>	<p>1 2 3 4 5</p>	<p>1 2 3 4</p>

General features of prewired switches FA-FB-FF series

Outline dimensions (All measures in the diagrams are in mm or degrees)

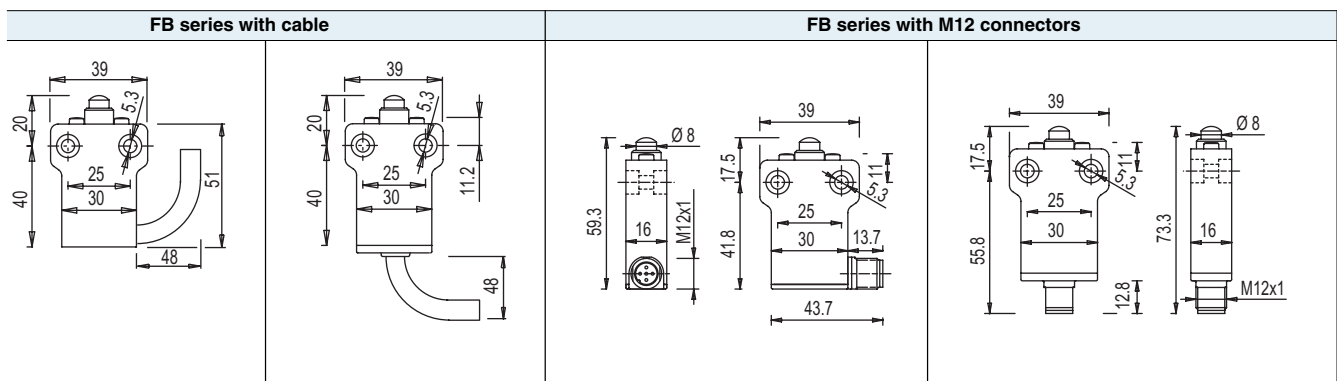
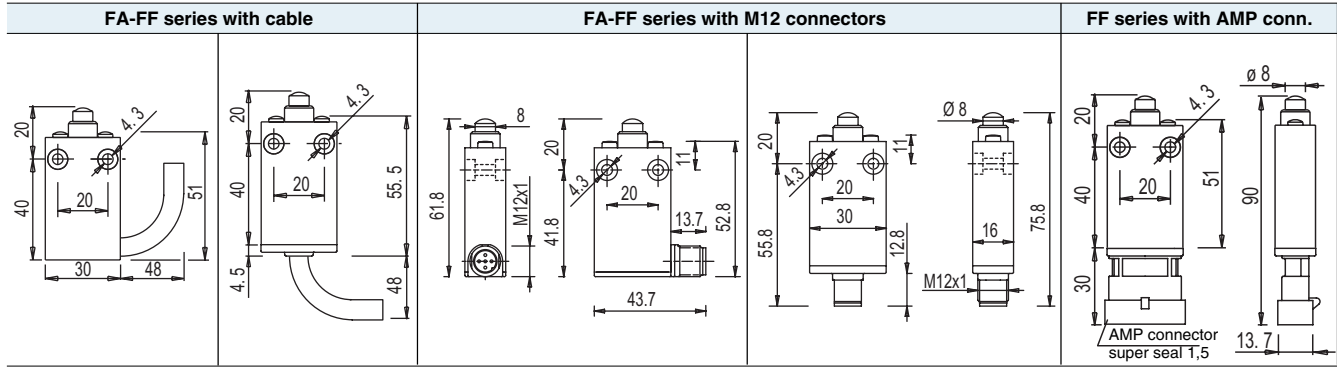

Minimal bending radiuses (All measures in the diagrams are in mm or degrees)

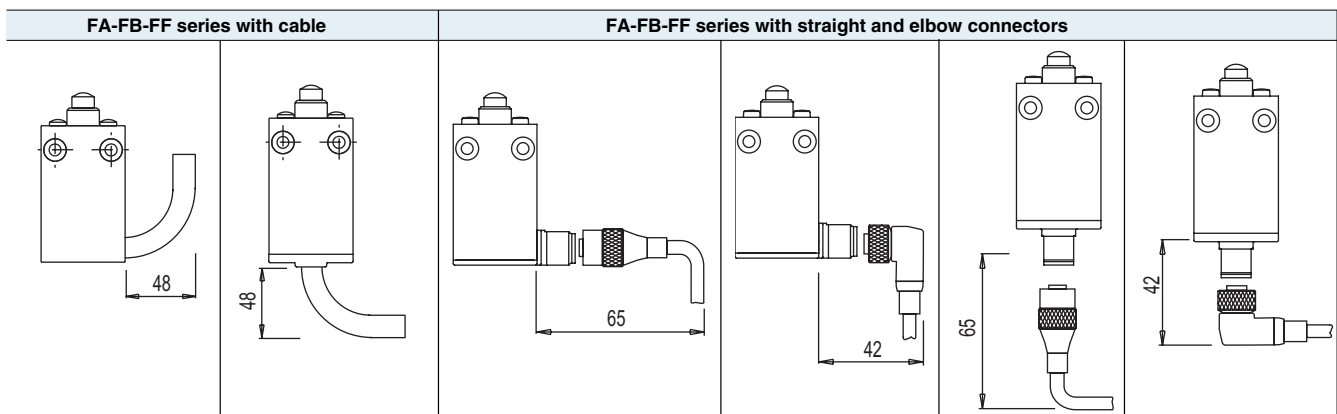

Spacers for FA, FB, FF series

 10 pcs. packs



You can easily join two or more prewired switches by interposing some spacers between the switches. The spacers prevent the switches moving from one to another.

Article	Description
VF D16	Spacers for FA-FF series
VF D16B	Spacers for FB series

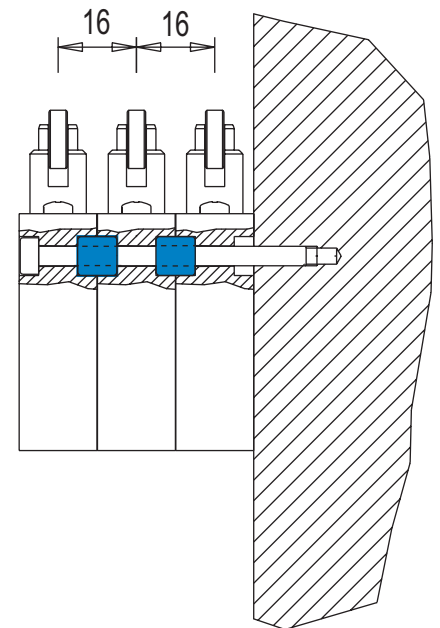
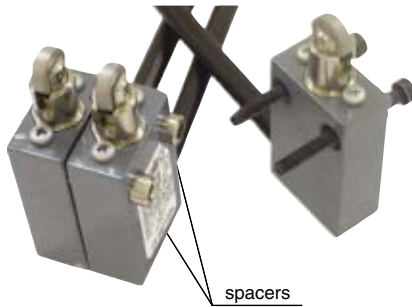

6.1

Accessories

For other accessories: **female wired connectors** see chapter 16.



On request

- Special version with oriented head.
- Special version with stainless steel parts.
- Custom-made special versions.